

UDC 656.7.084

DOI: 10.18372/2306-1472.70.11420

Svitlana Pavlova¹,
Olexander Volkov²

SYSTEM OF GUARANTEED RESOLUTION OF DYNAMIC CONFLICTS OF AIRCRAFTS IN REAL TIME

National Aviation University
Kosmonavta Komarova Avenue 1, 03680, Kyiv, Ukraine
E-mails: ¹psv@nau.edu.ua; ²alexvolk@ukr.net

Abstract

Purpose: The present work is devoted to improving of flight safety in civil aviation by creating and implementing a new system of resolution of dynamic conflict of aircrafts. The developed system is aimed at ensuring a guaranteed level of safety when resolution of rarefied conflict situations of aircraft in real-time.

Methods: The proposed system is based on a new method of conflict resolution of aircraft on the basis of the theory of invariance. **Results:** The development of the system of conflict resolution of aircraft in real time and the implementation of the respective algorithms such control will ensure effective prevention of dangerous approaches. **Discussion:** The system is implemented as single unified equipment using satellite and radar navigation systems that will ensure the positioning of aircraft in real time. Provided that the system should be installed on all aircraft and integrated on board to properly ensure its functionality and interact with navigation systems.

Keyword: aircraft; air traffic; civil aviation; conflict situation; threat of collision.

1. Introduction

Flight safety is largely connected with the task of collisions avoidance of aircrafts in the air. At present this task is entrusted to the air traffic controls of air traffic control systems, aircraft crew and airborne collision avoidance systems. However, with the growth of air traffic the air traffic controls (ATC) and aircraft crews face increasing difficulties of preventing dangerous approaches of aircraft in the air.

Technical means and collision avoidance systems installed on board the aircraft no longer meet the modern requirements and do not provide the required level of safety [1].

2. Relevance

Visual methods used in the piloting, do not provide the necessary safety, as even in very good visibility the pilots in some cases find a counter aircraft when the time for the execution of the avoidance maneuver is still not enough. In addition, visual methods are associated with subjective errors in determining the distance to the aircraft, its speed and in assessing the degree of risk of collision [2].

The existing ATC system, due to overloads of air traffic controllers in the control process and some

limitations of technical means also does not fully ensure the control of maintaining the prescribed navigation parameters with each aircraft flying on instruments. In addition, the ATC system does not allow for the control of flights in all airspace, especially at low altitudes and in difficult to monitor areas (the mountains, tundra, the poles, the oceans etc.).

A very effective means of improving the reliability and operability of ground-based ATC is the automation of supervision and mission control, the introduction of more advanced system of radar, computer systems, and information display systems.

We can say that the ATC automation is the Foundation of dispatching control supervisory control over flying aircraft and the introduction of automated systems now greatly improves the efficiency and safety of air traffic, reduces strain on dispatchers and pilots.

We can say that the ATC automation is the basis for the development of means of ground control of flight control of the aircraft and that the introduction of automated systems has already significantly improves the efficiency and safety of air traffic, reduces the workload of controllers and pilots. However, the automation of processes to ensure safety and improve radar equipment cannot

adequately provide the avoidance of dangerous approaches on the routes with heavy traffic in hard-to-reach areas and when intercontinental flights [3].

3. Analysis of recent research

There are two concepts when considering the problems of avoidance collisions of aircrafts in the air: dangerous approach of aircraft and aircraft collision. The dangerous approach of aircrafts is the situation in which the aircrafts closer to the minimum distance, even when it is possible to prevent a collision by executing evasive maneuvers. The collision is the situation in which the aircraft approached at a distance equal or less than the safe distance parting.

There are several modern aircraft collision avoidance systems [4].

The system of prevention of dangerous approaches of aircraft in the air (TCAS – Traffic Collision Avoidance System) is used today to reduce the risk of collisions of aircrafts. There are various options of this system. ICAO (International Civil Aviation Organization) recommends the use of TCAS II system, as it is now fully complies with the ACAS (Airborne Collision Avoidance System) and installed on most commercial aircraft. TCAS II system can detect aircrafts at distances up to 40 miles, provides information about air situation and direct advice on how to resolve the conflict. The system can simultaneously track up to 30 aircraft and to issue commands to resolve conflict simultaneously for three aircraft.

While the advantage of using the TCAS is undeniable, this system has a number of significant restrictions:

- ATC does not receive instructions issued by the TCAS aircraft, so air traffic controllers may not have enough information, and also give conflicting guidance that is the reason for the uncertainty in the actions of the crews;

- it is necessary for the efficient operation of the TCAS, all aircraft were equipped with this system, as the aircraft detect each other at the transponders;

- the system fails to detect aircraft not equipped with transponders. If for some reason the sensor of the conflicting aircraft does not give data on its altitude, the system may not identify it on the display;

- to correct a conflict, the system generates commands for maneuvering only in the vertical plane, maneuvers in the horizontal plane remain for it impossible.

Within the framework of the project "iFly" [5] Eurocontrol has attempted to develop a new system for safe separation ASAS (Airborne Separation Assurance (Assistance) System). ASAS is an on-board system that allows the crew to maintain safe separation of aircraft and provides the necessary information on air traffic. One of the basic functions of ASAS is to improve crew situational awareness, which is to provide him with all necessary information about the air traffic around its own aircraft to make the right and timely decisions to ensure separation with other aircraft.

The project provides that the distance between aircrafts is reduced, and this, in turn, requires the development of a system to prevent aircraft "Wake." Algorithms of ASAS in general are not yet standardized. This is due to the complexity of the transition to the new principles for the allocation of responsibility between an air traffic controller and a pilot to support safe aircraft separation. The above can be attributed to the main shortcomings of the system.

Consider also new technology automatic dependent surveillance ADS-B (Automatic Dependent Surveillance-Broadcast), which is an advanced method of ADS (Automatic Dependent Surveillance). ADS-B technology, now being implemented on the territory of the United States and in other countries, allows pilots in the cockpit and air traffic controllers on the ground to "see" traffic of aircraft with more precision than was available previously, and to obtain aeronautical information [6-7].

ADS-B also transmits real-time weather information to pilots. This information greatly enhances the pilot's awareness of the situation and increases safety. In addition, access to ADS-B information is free. Any user that is in the air or on the ground within range of the broadcast transmission may process and use this information for their own purposes. This information may be used by ATC and ACAS.

Disadvantages of ADS-B [8-10]:

- the absence of any means of protection during data transfer;

- ability to send broadcast fake data or replace information in these data packets;

- party accepting these packages cannot be confident of the validity of the package and identify the sender.

4. Highlighting the unresolved part of the problem

Based on the above described can be concluded.

Developed and implemented modern systems and technologies of conflict resolution of aircrafts have significant drawbacks that do not provide a guaranteed level of safety. The system of conflict resolution of aircrafts must synthesize recommendations in the presence of a detected conflict, which should provide in general the spatial avoidance maneuver to prevent a possible dangerous approach of aircrafts, and after the conflict resolution to ensure the aircraft return to the planned trajectory and it's further maintaining. In the process of issuing recommendations for execution of maneuver the optimality criteria (fuel consumption, time and space cost of performing the maneuver, the comfort of passengers, etc.) should be taken into account.

5. Statement of research problems

In this regard, at present, to solve the problem of collision avoidance is considered technically and economically feasible to supplement the ATC system special onboard collision avoidance system of aircraft capable of autonomous, independent from the ATC system, in real time, to provide a safe separate of aircraft when there is a threat of collision.

The purpose of this work is the creation of a new system and technology resolution of dynamic conflict situations of aircraft with maintenance of the guaranteed level of flight safety.

To avoidance collisions with aircraft through ATC technical means must be made:

- measurement location coordinates and parameters of aircraft motions;
- prediction by simulation with the specified steps possible positions of aircraft after a certain time to detect the threat of collision;
- information exchange with aircrafts for warning and coordinate their maneuvers to avoid collisions;
- ensure the implementation of an automated process resolution of conflict situation.

It is precisely such functional tasks are put for the creation of the new system of dynamic conflicts resolution of aircraft for the organization of decentralized control of air traffic in the modern conditions of safety.

6. System of guaranteed resolution of dynamic conflicts of aircrafts in real time

We propose a solution system of dynamic conflicts aircraft (with necessary and sufficient time) in real time to enhance the security of aviation and aeronautical engineering efficiency.

The paper proposes a system of guaranteed resolution of dynamic rarefied (with necessary and sufficient lead time) conflicts of aircraft in real time to improve safety in aviation and aeronautical engineering efficiency.

The system is implemented as single unified equipment that works using satellite and radar navigation systems that will ensure the positioning of aircraft in real time. Provided that the system should be installed on all aircraft and is integrated into onboard systems to adequately ensure its functionality and interact with navigation systems.

The block diagram of the system is presented in Fig.1. As shown, the system of resolution of dynamic conflict of aircrafts (1) operating in real time consists of two modules that contain blocks, and some individual blocks that perform additional functional tasks.

The system contains the following modules:

- the module for determining the threat of collision (4);
- the module of calculation of maneuvering parameters (9).

In turn, the module for determining the threat of collisions include: the block determining the aircraft coordinates (5), the block of calculation of projected motion paths (6), the block of data analysis and definition of the threat of collision (7) and the accounting block "zones of uncertainty" (8).

The module of calculation of maneuvering parameters includes: the block computation and comparison of "controllability areas" (10), the block prioritizing and selecting the type of maneuver (11), the block determining the trajectory maneuver (12), the block determine the trajectory of the return to the initial trajectory (13), the global optimum (14) (temporal and spatial assessment of losses in performing the maneuver to resolve conflict situations).

In addition, the system contains several separate blocks, namely:

- the data reception block (2);
- the data processing block (3);
- the issuing control commands, alarms and indication (15).

Consider the principle of operation of the system. The system to ensure its work obtains information from: on-board computer (A), radar systems (B), air data system (C) and flight navigation systems (D), inertial systems (E) and control system of engine and control surfaces (F). Information from these subsystems comes first on the data reception block and contains information about all aircraft within a specified limited part of space, their motion parameters, altitude, speed, acceleration, heading, information about the priority and additional parameters of their mathematical model. In addition, information about the aircraft, its flight parameters and characteristics is also supplied to the system.

The data processing block provides digital data processing, check and, if necessary, a certain accumulation of information. Then the information goes to the input of the module for determining the threat of collisions.

This module, using the block determining the aircraft coordinates, the block of calculation of projected motion paths, the block of data analysis and definition of the threat of collision and the accounting block "zones of uncertainty" provides the coordinates of all aircraft to the space-time grid. Possible "zones of uncertainty" of the locations of the aircrafts is added to the obtained coordinate values of the aircrafts in the airspace. Further, aggregate information from all the received data on the aircraft is used to calculate and simulate the predicted trajectory of each of them. The data obtained is analyzed and the determination of risk of collision of the aircraft is modeled. In the absence of such a threat the system cyclically resumes. In case there is a threat of collision information is passed to the module of calculation of maneuvering parameters.

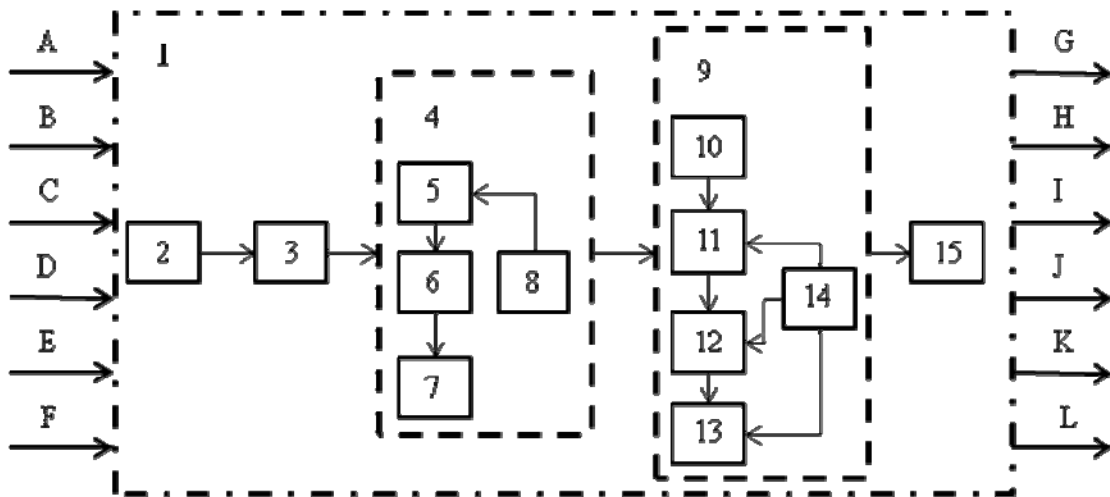

Fig. 1. Block diagram of the system

Module calculation of maneuvering parameters uses the information to determine the necessary changes of the aircraft motion and ensure relevant economic indicators, namely route optimization maneuver by distance and time, fuel economy, facilities for the carriage of passengers and luggage. These indicators and criteria in the future are taken into account when calculating and determining trajectories maneuver. These indicators and criteria in the future are included in the calculation and determination of trajectories of avoidance. In addition, the block computation and comparison of "controllability areas" calculates controllability areas ("controllability areas" based on the models of kinematics and dynamics of motion of the aircraft describe the capabilities of the aircraft to modify the motion at any point in time and allow to consider the

nonlinearity behavior of the aircraft) for each of the aircraft involved in a conflict at any time. Based on these results the analytical selection of the aircraft or set of aircraft, which will perform the avoidance maneuver is performed (is determined on the basis of an analysis of "controllability areas" of the aircraft involved in the conflict to prioritize and the type of maneuver is determined (the height, speed, heading or a combination of these). Further information is given on the block determining the trajectory maneuver, where the calculation and determination of the trajectory of the avoidance maneuver of a particular aircraft occurs. This module also provides the calculation and determination of the trajectory of the return to the initial trajectory.

To generate control commands the information is supplied to the onboard computer, the display system and alarm systems in the crew cabin (G), the control stations on earth (H), radar systems (I), autopilot (J), flight control and navigation complexes (K) and systems of communication and data transmission of the aircraft (L). In addition, the control commands in the form of supplementary information through feedback transmitted to the data processing block to ensure the cyclic operation of the system.

7. Conclusions

Creating the system of guaranteed resolution of dynamic conflicts of aircrafts in real time and implement such control relevant algorithms will ensure effective avoidance of dangerous approaches.

The developed system of dangerous approaches to authorization will provide difference aircraft relative to each other at a distance corresponding to the norms of separation, in the context of complex multiple conflicts, including a large number of aircraft (up to 50) and with extremely complex geometry (intersection of two dense traffic, intersection at one point and at the same time, a conflict with a combination of intersections and overtaking several aircraft at one point, etc.). The developed system of detection and resolution of dangerous approaches will provide a separation of the aircrafts relative to each other at a distance corresponding rules of aircraft separation, in a complex of multiple conflicts involving large (up to 50) number of aircraft and extremely complex geometry of the conflict (the intersection of two dense streams of aircraft converge at the same point and at the same time aircraft flying in different directions, a conflict with a combination of intersections and overtaking several aircraft at one point, etc.).

Control commands are generated automatically, simultaneously with other participants in air traffic.

There is the principal possibility to implement effective control as in the present structure and intensity of traffic flows, and when switching to perspective the principles of "FreeFlight".

Developed and implemented communication, navigation and surveillance systems in the coming years will provide the technical possibility to organize decentralized control of air traffic. Determined flight parameters on board each aircraft by volume, frequency of updates and precision are

sufficient for effective use for system of conflict resolution of aircrafts.

References

- [1] Volkov A.E., Pavlov V.V., Volosheniuk D.A. Invariantnaya setetsentricheskaya sistema upravleniya konfliktnymi situatsiyami vozdukhnykh korably na etape zahoda na posadku [The invariant network-centric of conflict management system of the aircraft on the approach phase]. *Zhurnal nauchnykh trudov "Kibernetika i vyichislitel'naya tekhnika"*, 2015, issue no. 180, pp. 45-65. (In Russian).
- [2] Druzhinin V.V., Kontorov D.S. *Konfliktnaya Radiolokatsiya* [The Conflict Radiolocation]. Moscow, Radio i svyaz Publ., 1982, 62 p. (In Russian).
- [3] Ahmedov R.M., Bibutov A.A., Vasilev A.V. *Avtomatizirovannyye sistemy upravleniya vozdukhnyim dvizheniem: Novyye informatsionnyye tekhnologii v aviatsii* [The Automated Air Traffic Control System: New Information Technologies in Aviation]. Moscow, "Politehnika" Publ., 2004, 446 p. (In Russian).
- [4] Chepizhenko V.I., Volkogon V.O. [The role of modern concepts of transformation CNS / ATM systems to provide autonomous flight of aircraft]. *Mizhnarodna konferentsiya "Aktualni problemi avtomatizatsiyi ta informatsyinh tekhnologiy"* [International conference "Actual problems of automation and information technology"]. Kyiv, 2015, vol. 19, pp. 112-120 c. (In Ukrainian).
- [5] ASAS Self Separation. iFly: Airborne Perspective, 2014. Available at: http://www.asas-tn.org/towards-asasgn/session-3/3_ifly_2.pptx (Accessed 29 August 2016).
- [6] FAA Office of Public Affairs, "FAA Announces Automatic Dependent Surveillance-Broadcast Architecture", 2002, APA 27-02 p.
- [7] Krozel J., Peters M. *Decentralized control techniques for distributed air/ground traffic separation*. Los Gatos, Seagull Technology Inc., 2000, 104 p.
- [8] Belkin A.M., Mironov N.F., Rublev Yu.I., Sarayskiy Yu.N. *Vozdushnaya navigatsiya: spravochnik* [Air navigation: A Handbook]. Moscow, "Transport" Publ., 1998, 284 p. (In Russian).
- [9] Korolev E.N. *Tekhnologii raboty dispetcherov upravleniya vozdukhnyim dvizheniem* [Technology operation of air traffic controllers].

Moscow, Vozdushnyiy transport Publ., 2000, 541 p. (In Russian).

[10] Voynich B., Pozdnyakova O., Sosnivskiy A., Borisov V. *Predotvraschenie stolknoveniy vozdushnyih sudov. Avtonomnaya mikroelektronnaya radiolokatsionnaya sistema* [Aircraft collision avoidance. The

autonomous microelectronic radar system]. Moscow, Elektronika Publ., 2000, 369 p. (In Russian).

Received 07 March 2017

С.В. Павлова¹, О.Є. Волков²

Система гарантованого вирішення динамічних конфліктів повітряних кораблів в масштабі реального часу

Національний авіаційний університет, просп. Космонавта Комарова, 1, Київ, Україна, 03680

E-mails: ¹psv@nau.edu.ua; ²alexvolk@ukr.net

Мета: Робота присвячена питанням підвищення безпеки польотів у цивільній авіації шляхом створення її впровадження нової системи розв'язання динамічних конфліктних ситуацій між літаками. Розроблена система спрямована на забезпечення гарантованого рівня безпеки при розв'язанні розріджених конфліктних ситуацій між літаками в масштабі реального часу. **Методи дослідження:** Пропонується система розв'язання динамічних конфліктів повітряних кораблів з метою підвищення рівня безпеки польотів, заснована на новому методі розв'язання конфліктів повітряних кораблів, з використанням теорії інваріантності. **Результати:** Створення системи розв'язання динамічних конфліктних ситуацій повітряних кораблів в масштабі реального часу і реалізація потрібного управління відповідними алгоритмами для забезпечення ефективного запобігання небезпечних зближень. **Обговорення:** Система реалізується у вигляді окремого уніфікованого обладнання, що працює з використанням супутникових та радіолокаційних систем навігації, що дозволить забезпечити визначення координат повітряних кораблів в масштабі реального часу. Передбачено, що система повинна бути встановлена на всі повітряні кораблі і інтегрована в бортове середовище для належного забезпечення її функціональності і взаємодії з бортовими навігаційними системами.

Ключові слова: загроза зіткнення; конфліктна ситуація; повітряний рух; повітряне судно; цивільна авіація.

С.В. Павлова¹, А.Е. Волков²

Система гарантированного разрешения динамических конфликтов воздушных судов в масштабе реального времени

Национальный авиационный университет, просп. Космонавта Комарова, 1, Киев, Украина, 03680

E-mails: ¹psv@nau.edu.ua; ²alexvolk@ukr.net

Цель: Настоящая работа посвящена вопросам повышения безопасности полетов в гражданской авиации путем создания и внедрения новой системы разрешения динамических конфликтных ситуаций между самолетами. Разработанная система направлена на обеспечение гарантированного уровня безопасности при разрешении разреженных конфликтных ситуаций между самолетами в реальном масштабе времени. **Методы исследования:** Предлагается система разрешения динамических конфликтов воздушных судов с целью повышения уровня безопасности полетов, основанная на новом методе разрешения конфликтов воздушных судов с использованием теории инвариантности. **Результаты:** Создание системы разрешения динамических конфликтных ситуаций воздушных судов в масштабе реального времени и реализация необходимого управления соответствующими алгоритмами для обеспечения эффективного предотвращения опасных сближений. **Обсуждение:** Система реализуется в виде отдельного унифицированного оборудования, работающего с использованием спутниковых и радиолокационных систем навигации, что позволит обеспечить определение координат воздушных судов в масштабе реального времени. Предусмотрено, что система должна быть установлена на все воздушные суда и интегрирована в бортовую среду для

надлежащего обеспечения её функциональности и взаимодействия с бортовыми навигационными системами.

Ключевые слова: воздушное движение; воздушное судно; гражданская авиация; конфликтная ситуация; угроза столкновения.

Pavlova Svitlana (1966). Doctor of Engineering. Professor.

Department of air navigation systems, National Aviation University.

Education: Kyiv Civil Engineering Institute, Kyiv, Ukraine (1988).

Research area: analysis and synthesis of nonlinear ergatic systems, critical technology, nonlinear dynamics.

Publications: 150.

E-mail: psv@nau.edu.ua

Olexander Volkov (1990). Post-graduate Student.

Senior Engineer, Department of air navigation systems, National Aviation University.

Education: National Aviation University, Kyiv, Ukraine (2013).

Research area: flight dynamics, intelligent control of dynamic objects.

Publications: 70.

E-mail: alexvolk@ukr.net