

TRANSPORT SYSTEMS

UDC 681.586:620.172.21:629.735.05 (045)

DOI: 10.18372/1990-5548.57.13243

¹A. P. Kozlov,
²R. L. Pantyeyev

MULTIFUNCTIONAL ROBOTIC COMPLEX BASED ON A SINGLE-BOARD COMPUTER

^{1,2}Aviation Computer-Integrated Complexes Department, Educational & Scientific Institute of Information and Diagnostic Systems, National Aviation University, Kyiv, Ukraine
E-mails: ¹ap_kozlov@ukr.net, ²romanpanteevmail@gmail.com

Abstract—The necessity of organization and implementation of the aircraft elements deformations continuous control for the timely detection of their critical values is shown. A brief overview of existing methods and devices for measuring micro-displacement is given. The variants of constructions of micro-displacement sensors are offered and the structural scheme of the meter, built on the basis of a capacitive transducer with an "open" field, is presented. The system for contactless measurement of the aircraft elements deformations is considered. The proposed measurement scheme allows us to solve the problem of switching radiating electrodes and to fully automate the operation of the system of continuous control of the state of the aircraft construction.

Index Terms—Operating resource; aircraft; elastic deformation; capacitive sensor; sensitive element; critical deformation; control system.

I. INTRODUCTION

Operating resource of the aircraft (AC) to a large extent depends on the strength and rigidity of its design. In the process of developing a new AC, these parameters are tested by a mandatory test set. This complex includes static, dynamic and summer tests as separate elements and components of the design, as well as the PC as a whole. The latter is decisive for assessing the strength of the structure. During static tests, residual deformations are determined after the removal of the experimental load, the distribution of forces on individual elements of the structure, the value of the maximum load that can withstand the structure before fracture. Dynamic tests are conducted to detect fatigue deformations. This, in front of all, relates to various bolts, rivets, welds and other joints. Summer tests are designed to verify the results of ground tests in real conditions. Test results largely depend on methods and means of the controlled parameters measuring [1].

During operation, the AC design, its aggregates and individual parts are under the influence of various loads. In this case, for some parts of the aircraft and its aggregates, the most dangerous can be the forces operating in flight, for others – during take-off and landing. The nature of these forces may be different. Constant – from the loading of the aircraft, the lifting force, the variable – from the action of aerodynamic forces, episodic – from shock loads in the case of an unusual situation. As a result of these forces accumulate fatigue deformations characterized by a gradual increase in irreversible

changes in the structure of the material and the emergence of micro cracks with the subsequent formation of the main macro crunch, which leads to the destruction of the structure.

It is known that for elastic deformation, the structure recovers its shape after the external forces termination, and the appearance of plastic deformation signals the beginning of the process of destruction of the structure.

Maintenance of the AC elements is carried out in accordance with the regulations, which provides the repair or replacement of the individual units and elements of construction in accordance with the requirements of the operational documentation. The terms, composition and procedure for the execution of scheduled work are based on the results of pre-operational tests. During operation, inter-regulatory control of the state of the PC design is only occasional. This is the case when micro cracks are searched after a rough, unsuccessful landing, runway, and so on. If the AC has exhausted its operational lifetime determined by the regulations, it is removed from operation and written down, despite the fact that its state may still allow further operation. However, there are known cases where the destruction of any element of the construction occurred before the end of the resource provided by the regulations, this often ended with an accident. Consequently, all this points show the necessity for the AC elements technical state monitoring system. Such control will reduce the construction accidental destruction probability during operation, and also will allow prolonging the AC lifetime in the case of the construction regular state at

the end of the statutory term. Such control will reduce the accidental destruction probability of the construction during the operation, and also will allow prolonging the AC lifetime in the case of regular construction state at the end of the statutory term. This is useful both in terms of flight safety and economically.

II. OBJECTIVES SETTING

For the continuous monitoring organization and implementation of the AC construction state, the following should be solved:

- identify the construction elements in which the most probable occurrence of destructive deformations;
- develop the measuring tools complex and methods of their use.

It is quite complicated and can not be solved within a short time. However, solutions can be outlined. The analysis of accident and flight events indicates that the greatest number of fractures occurs at the junctions of the fuselage wing, in the places

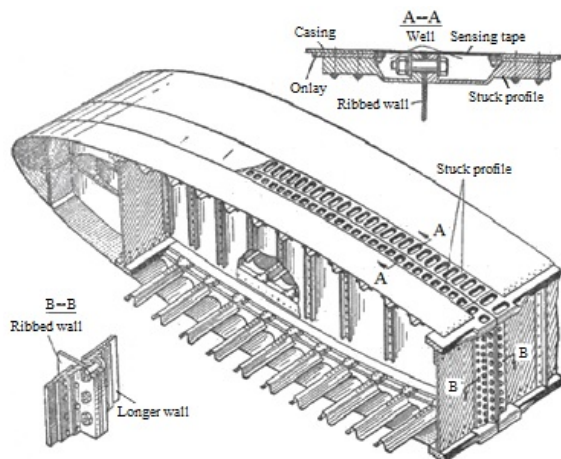

Fig. 1. Construction of the contouring fastening of the wing, which is carried out with the help of joints profiles

III. SOLUTION FINDING TO THE PROBLEM OF MEASURING CRITICAL DEFORMATIONS

Given the measuring deformation existing means follow the next steps. All methods for measuring linear and angular dimensions can be divided into contact and non-contact. In the contact method, the primary converter is in direct contact with the object under study. In the contact method, the primary converter is in direct contact with the object under study. A more convenient contact instrument for measuring deformations is widely used strain gauges that are fastened with glue in the zone of supposed critical deformations. But the range of strain gauges measured is very limited, the preparation and

where the engines are mounted on the wings and in the fastening elements that fasten the chassis. However, solutions can be outlined. The analysis of accident and flight events indicates that the greatest number of fractures occurs at the junctions of the fuselage wing, in the places where the engines are mounted on the wings and in the fastening elements that fasten the chassis. Thus, placing in these deformation zones sensors with the transfer of the received information to the on-board computer for further processing is most appropriate for solving the specified task.

For the measuring instruments selection and their placement on the AC construction elements, some of the most commonly used interlocking fastener constructions are considered. The wing contouring fastening construction is shown in Fig. 1 [1].

Analyzing possible loading of these elements, it could be assumed that the most probable zone of the dangerous strains appearance will be joints in the areas of their subtle intersection.

In Figure 2, another construction of the site is considered, which also uses the junction profile for the micellar joint.

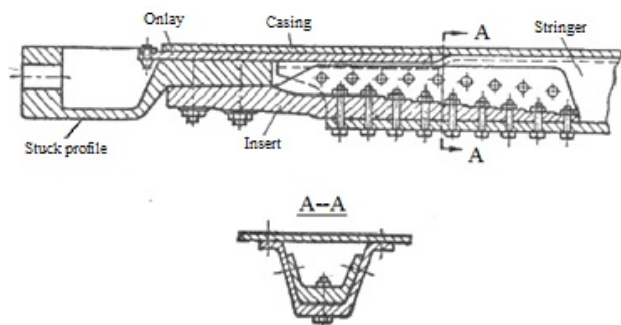

Fig. 2. Node construction that connects the joist profile with lining and stringers

fastening of the sensors are very demanding and require considerable time expenditures, the mounting is unreliable for long-term use, it is necessary to provide compensation for the temperature instability of the measurements, shock loading strain gauges do not withstand even within the limits of permissible deformations. Therefore, strain gauges are used mainly for static tests.

In the noncontact method of measurement, the primary converter does not directly interact with the object under study and does not distort its parameters.

According to the physical laws, based on the principle of action, contactless transducers of non-electric quantities in electric can be divided into inductive, capacitive, optical and ultrasonic [2], [3].

The analysis of the devices implementing these methods shows that it is more expedient to use capacitive sensors to measure deformations by contactless method.

Capacitive sensors are based on the input value transformation into the variable capacitance. Capacitance is determined by its constructive parameters and dielectric permittivity of the medium between the plates. Common capacitive sensors that convert the measured geometric parameter into a capacitance by changing the gap between the covers (electrodes) of the capacitor. But to measure structural deformations, only a one-sided approach to a controlled surface is possible. In addition, the sensor capacity value due to the miniature design of the sensor probe is very small, which complicates the measurement. These circumstances make it necessary to create such capacitive sensor and + measuring circuit that would be suitable for solving the task.

The closest technical solution is to measure micro-displacement, designed to control the shape change of construction during electric welding [4].

The device was designed to measure the micro-displacements of the control point resulting from the thermal deformation of the metal sheet during the welding process. The sensing element of the device (probe) is the differential capacitive converter with an open field (Fig. 3). The range of measured displacements was 1.2 mm, the measurement error was no more than 0.003 mm. The displacement can be measured in two coordinates alternately. The probe design has a round housing, which contains electrodes system of the capacitive converter, forming an electromagnetic field. Electrodes 1 , $1'$ and $1''$, $1'''$ (two last ones in the figure are not indicated) – high-potential electrodes, which are pairwise located in mutually perpendicular planes, and 2 is a low-potential electrode. The "Mask" of the probe 3 together with the case 4 and the copper tubes-screens 5 are intended to avoid the parasitic capacitances influence of the sensor connecting conductor. The sensor probe is placed above the "checkpoint". "Checkpoint" is a metal cylinder whose diameter is equal to the width of the low-potential electrode 2 , and a height of 1 mm, with the thin cylindrical base, which is glued to the controlled surface. The electrodes system allows, for the various connecting variants of the electrodes to the measuring circuit, to obtain more information about the current deformation, in particular, about the direction and magnitude of the micro-displacement in the controlled surface plane, and also (with the corresponding connection) about the distance to the controlled surface, that is, one can measure displacement in three coordinates alternately [4].

The device under consideration can be used to control the deformation of the AC components.

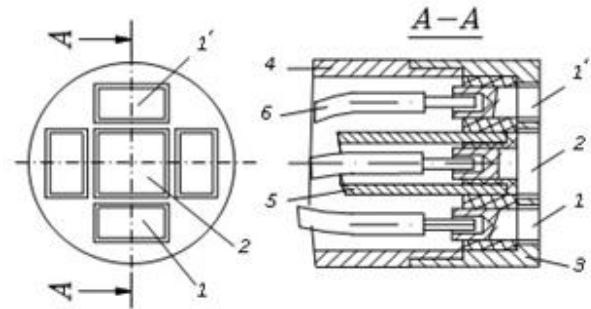

Fig. 3. Capacitive microsatellite sensor probe ($1, 1'$ – high-potential electrodes; 2 is the low-potential electrode, 3 is the probe "mask"; 4 is the casing; 5 is the low power electrode screen)

IV. SENSITIVE ELEMENT DESIGN AND ITS PLACEMENT IN THE CONTROL ZONE

Taking into account the above, developed design variants of the sensitive element. The deformation sensor sensitive element design of the buttress profile and its placement is shown in Fig. 4.

Given that the most likely plastic deformation occurrence in the bolted connections zone, it is advisable to place the similar device at the bolts ends of such design, and one of these ends can be used as the "control point".

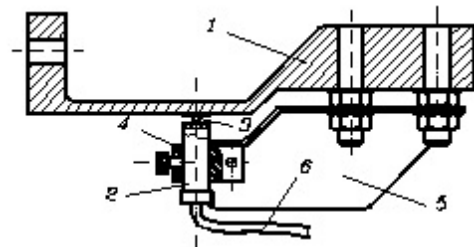

Fig. 4. Sensing element placement of the sensor (probe) for the joint profile deformation control (1 is the buttress profile, 2 is the probe, 3 is the control point, 4 is the probe hold, 5 is the fixing shaped box, 6 are connecting lines)

The application of the proposed device enables the use of the rivet heads, construction elements, and other AC geometric inhomogeneity as the "control point". If the measured deformation has a known change nature, then the probe design can be simplified for one coordinate measuring. The design of the sensor has one feature, which is related to the measurement of excessive capacitance values. The connecting lines must be rigidly shielded, so they are placed in copper tubes of the corresponding small diameter.

It is planned to install the considered sensors set at the AC assembly final stage, or at the major repairs stage.

V. DESIGN OF THE DEVICE MEASURING SCHEME

The main difficulty of using the device under consideration is the need to measure excessive capacitance values. It is known that bridge methods allow such capacitance measurements to be carried out with the fairly high accuracy. The greatest accuracy of the capacity measurement is provided by transformer bridges with a multi-filament winding system and the three-electrode connection of the capacitive sensor to the measurement circuit [5]. In the simplified case, the measuring circuit is the differential unbalanced transformer bridge (Fig. 5). The scheme works in this way. If the sensor probe is placed symmetrically relatively to the reference point of the KT, the measuring bridge will be balanced, the capacity C_{12} (the capacity between the electrodes 1 and 2) is equal to the capacity C_{32} (the capacity between the electrodes 3 and 2). The symmetry of the electromagnetic field is considered only in one plane, because electrodes in the perpendicular plane in this case are grounded. With some shifting of the control point there is an asymmetry of the electromagnetic field, the equality of capacities is broken, the bridge is balanced, at the output of the amplifier there is a signal about the deformation. When there is no load on the structure, the bridge becomes equilibrium. But, if there is a plastic deformation, then some signal will remain at the output of the circuit. Naturally, during the flight of the aircraft elements of the structure undergo random variable loads. But, if we estimate the mathematical expectation of deformation signals, then its value will detect the appearance of plastic deformation. The zero value of mathematical expectation indicates elastic deformation, irreversible deviation from zero indicates the presence of plastic deformation. Placing a set of sensors in the areas of the most likely appearance of plastic deformation can be carried out continuous monitoring of the state of the design.

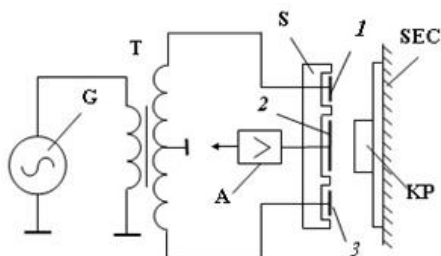

Fig. 5. Sensor of deformation (functional diagram) (G is the power meter for the measuring bridge; T is the shoulder transformer bridge; A is the amplifier; 1,3 are high-potential electrodes; 2 is the low-potential (receiving) electrode; S is the body-screen of the sensor; KP is the control unit; SEC is the surface of the controlled AC construction element)

For the high-precision and reliable measurement of critical deformations in view of the proposed and investigated scheme for the placement of radiating and receiving electrodes on a measuring probe, a four-channel noncontact sensor of critical deformations, the functional diagram of which is shown in Fig. 6.

Measurement scheme, as shown in Fig. 7, consists of the following components:

- capacitive converter;
- power generator;
- multi-armed transformer bridge to which the system's electrodes are connected;
- four amplifiers;
- eight mathematical addicts;
- four stabilizing reference capacitors.

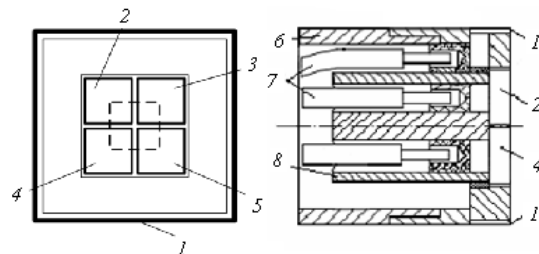

Fig. 6. Probe of capacitive sensor of critical deformation (1 is the high-potential electrode; 2,3,4,5 are low-potential electrodes; 6 is the casing; 7 are outputs; 8 are screen of low-potential electrodes)

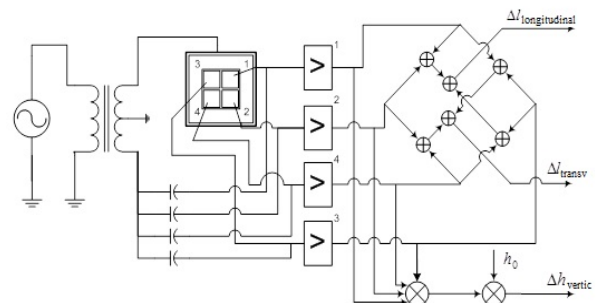

Fig. 7. Functional diagram of a four-channel noncontact sensor of critical deformation

This device measures the movement of a reference point at the location of the most probable deformation in three coordinates:

- for information on the deformation in the longitudinal direction, the difference in the amounts of information capacities from the electrodes 1, 2 and 3, 4, respectively, is measured;
- for information on the deformation in the transverse direction, the difference of the amounts of information capacities from the electrodes 1, 3 and 2, 4, respectively, is measured;
- the amount of information capacities from all electrodes has information about the deformation in the vertical direction.

VI. SYSTEM OF CONTACTLESS MEASUREMENT OF AC CONSTRUCTION ELEMENTS DEFORMATIONS

The developed system of AC elements critical deformations control is shown in Fig. 8.

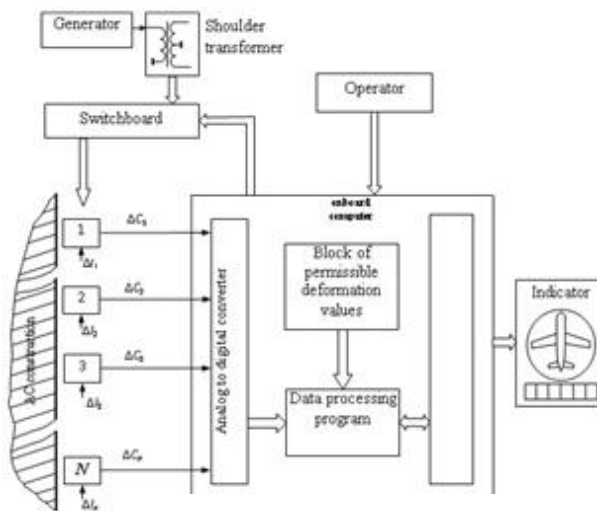

Fig. 8. AC construction critical deformations control system

The system consists of the micro-displacement sensors set 1, 2, 3, ..., N , located on the controlled AC elements, bridge power generator, shoulder transformer, switch for measuring coordinates, on-board computer (BC) or its parts with a separate system for the processor and a state of the indicator for monitoring. BC should have several (by number of controlled areas) multichannel analog-to-digital ADC converters. The permanent memory device loads a data processing program, a system operation program, and a database of deformation values at controlled points. The operating modes of the system are set by the operator: the inclusion of control of all zones, the choice of a specific zone or even a specific sensor with the specified direction of control deformation. The received information enters the indicator, where the points of a dangerous state of the design are brightly illuminated on the PC circuit. The bottom of the indicator displays the value of the current and allowable deformation at the point requested by the operator.

VII. RESULTS

The AC elements monitoring system, the sensitive element design are proposed. It was shown the measuring circuit allows the AC elements continuous monitoring. The necessity for the AC elements technical conditions continuous control systems was also shown in this article. The design principle of the contactless measurement of the aircraft elements deformations was considered. The results of experimental studies of static

characteristics of micro-displacement sensor are presented and their analysis is carried out. The design of a capacitive converter is considered, which allows to obtain a linear static characteristic, as well as a structural scheme of a three-coordinate micro-displacement meter as the main element of the system.

As statistics of aviation accidents and disasters show, one of the reasons for their occurrence is the AC elements destruction. Therefore, one of the priority directions of the development of aviation engineering to ensure a high level of flight safety is the creation and implementation of systems for continuous monitoring of the technical state of the AC design.

One of the main characteristics of aircraft is the reliability, durability of their structures, which are detected during the operation and depend not only on the strength of the structure, but also on the intensity of external influences on the AC.

Now control of the operational and technical state of the AC is carried out in accordance with the regulations. The terms of the scheduled work are determined according to the statistics of the test tests with the maximum probability of failure. However, as the world practice shows, not always individual AC elements can function normally within the period of operation prescribed by the regulations, which in turn can lead to the failure of the main nodes or their destruction [1].

During operation on the design of the AC there are various loads, complex in nature and variables in time. As a result of these forces accumulate fatigue deformations characterized by a gradual accumulation of irreversible changes in the structure of the material and the emergence of plastic deformations and microcracks with the subsequent formation of the main macro crunch, which leads to the destruction of the structure. Most of the details and basic elements of the AC design are made of a variety of metals that have different characteristics of plasticity, hardness and durability of materials.

The general dependence of deformations of elastic metals on the load (Hooke's law), used during the creation of the main nodes of the consort of PC, is shown in Fig. 1 As can be seen from this graph, the site of the OA corresponds to the elastic deformation of the elements of the AC design, and the section AB characterizes the appearance of plastic deformation. Most of the design elements have a high degree of hardness and durability of the material and, accordingly, a very low degree of plasticity. Therefore, making the conclusion outlined, it is clear that any occurrence of plastic deformation is quite dangerous, since it can further

lead to the emergence of microcracks and as a consequence – to the destruction of the design of the AC. Such plastic deformations in aviation are called critical deformations of the AC design. Therefore, controlling the appearance of critical deformations of the main elements is extremely important for preventing the destruction of the AC design.

VIII. CONCLUSIONS

The essential disadvantage of controlling the operational and technical state of the AC under the regulations is that sometimes certain AC elements and nodes whose resource has expired can continue to be exploited as their technical condition meets all established norms, but they are decommissioned due to the expiration of the lifetime of the exploitation.

And that is why control of the deformations of the designs of the AC is important, as it is appropriate in terms of both flight safety and economic utility.

On modern ACs, diagnostic systems of automatic recognition of technical failures of equipment with the issuance of language warning pilot are used.

However, so far no modern AC has a system for continuous monitoring of the state of the AC design. Therefore, the creation of effective systems for the continuous monitoring of the state of the nodes and elements of the AC design is one of the priority directions of development of modern aviation engineering. Continuous control will reduce the probability of accidental destruction of the structure during operation and will allow prolonging the life of the PC in the case of regular construction after the expiration of the statutory term.

REFERENCES

- [1] R. Emden, *The fundamentals of aerostatic*. Moscow, 1936, 35 p. (in Russian).
- [2] V. E. Kuzmichev, *Laws and formulas of physics*. Directory. Kyiv, Naukova Dumka, 1989, 864 p. (in Ukrainian).

Received April 16, 2018

Kozlov Anatoliy. Candidate of Science. (Engineering). Associate Professor. Aviation Computer-Integrated Complexes Department, Education & Scientific Institute of Information-Diagnostics Systems, National Aviation University, Kyiv, Ukraine. Education: Kyiv State University named after T.G. Shevchenko, Kyiv, Ukraine, (1965). Research area: Capacitive Transducers with an Inhomogeneous Magnetic Field, Technological Measurements, Aviation Devices and Information Systems, Automation Systems Design. Publications: more than 50 papers. E-mail: ap_kozlov@ukr.net

Pantyeyev Roman. Candidate of Science. (Engineering). Associate Professor. Aviation Computer-Integrated Complexes Department, Education & Scientific Institute of Information-Diagnostics Systems, National Aviation University, Kyiv, Ukraine. Education: Donetsk National Technical University, Donetsk, Ukraine, (2001). Research area: Information Systems, Control Systems Design, Identification of Complex Systems, Mathematical Modeling. Publications: more than 20 papers. E-mail: romanpanteevmail@gmail.com

А. П. Козлов, Р. Л. Пантєєв. Система контролю стану конструкції літального апарата

Показано необхідність організації і виконання безперервного контролю деформацій елементів конструкції повітряного корабля для своєчасного виявлення їх критичних значень. Наведено короткий огляд існуючих методів і пристроїв вимірювання мікропереміщень. Запропоновано варіанти конструкцій датчиків мікропереміщень та наведено структурну схему вимірника, побудованого на основі ємнісного перетворювача з «відкритим» полем. Розглянуто функціонування системи безконтактного вимірювання деформацій елементів конструкції повітряного корабля. Запропонована вимірювальна схема дозволяє вирішити проблему перемикання випромінюючих електродів і повністю автоматизувати роботу системи неперервного контролю стану конструкції повітряного корабля.

Ключові слова: операційний ресурс; літак; пружна деформація; ємнісний датчик; чутливий елемент; критична деформація; система керування.

Козлов Анатолій Павлович. Кандидат технічних наук. Доцент.

Кафедра авіаційних комп'ютерно-інтегрованих комплексів, Навчально-науковий інститут інформаційно-діагностичних систем, Національний авіаційний університет, Київ, Україна. Освіта: Київський державний університет ім. Т.Г. Шевченко, Київ, Україна, (1965).

Напряг наукових досліджень: ємнісні перетворювачі з неоднорідним магнітним полем, технологічні вимірювання, авіаційні прилади та інформаційні системи, проектування систем автоматизації.

Публікації: більше 50 робіт.

E-mail: ap_kozlov@ukr.net

Пантєєв Роман Леонідович. Кандидат технічних наук. Доцент.

Кафедра авіаційних комп'ютерно-інтегрованих комплексів, Навчально-науковий інститут інформаційно-діагностичних систем, Національний авіаційний університет, Київ, Україна.

Освіта: Донецький національний технічний університет, Донецьк, Україна (2001).

Напряг наукових досліджень: інформаційні системи, проектування систем управління, ідентифікація складних систем, математичне моделювання.

Публікації: понад 20 робіт.

E-mail: romanpanteevmail@gmail.com

А. П. Козлов, Р. Л. Пантєєв Система контроля состояния конструкции летательного аппарата

Показана необходимость организации и выполнения непрерывного контроля деформаций элементов конструкции воздушного корабля для своевременного выявления их критических значений. Приведен краткий обзор существующих методов и устройств измерения микроперемещений. Предложены варианты конструкций датчиков микроперемещений и приведена структурная схема измерителя, построенного на основе емкостного преобразователя с «открытым» полем. Рассмотрены функционирования системы бесконтактного измерения деформаций элементов конструкции воздушного корабля. Предложенная измерительная схема позволяет решить проблему переключения излучающих электродов и полностью автоматизировать работу системы непрерывного контроля состояния конструкции воздушного корабля.

Ключевые слова: рабочий ресурс; самолет; упругая деформация; емкостной датчик; чувствительный элемент; критическая деформация; система контроля.

Козлов Анатолий Павлович. Кандидат технических наук. Доцент.

Кафедра авиационных компьютерно-интегрированных комплексов, Учебно-научный институт информационно-диагностических систем, Национальный авиационный университет, Киев, Украина.

Образование: Киевский государственный университет им. Т. Шевченко, Киев, Украина, (1965).

Направление научной деятельности: емкостные преобразователи с неоднородным магнитным полем, технологические измерения, авиационные приборы и информационные системы, проектирование систем автоматизации.

Публикации: более 50 работ.

E-mail: ap_kozlov@ukr.net

Пантєєв Роман Леонідович. Кандидат технических наук. Доцент.

Кафедра авиационных компьютерно-интегрированных комплексов, Учебно-научный институт информационно-диагностических систем, Национальный авиационный университет, Киев, Украина.

Образование: Донецкий национальный технический университет, Донецк, Украина (2001).

Направление научной деятельности: информационные системы, проектирование систем управления, идентификация сложных систем, математическое моделирование.

Публикации: более 20 работ.

E-mail: romanpanteevmail@gmail.com