

UDC 65.011.56:633.1 (045)

DOI: 10.18372/1990-5548.57.13241

¹V. M. Sineglazov,
²V. O. Kopaniev

INFORMATION SYSTEM FOR MEASUREMENT, TRANSMISSION AND PROCESSING OF PARAMETERS OF HYBRID POWER PLANTS

^{1,2}Aviation Computer-Integrated Complexes Department, Educational&Scientific Institute of Information-Diagnostics Systems, National Aviation University, Kyiv, Ukraine
E-mails: ¹svm@nau.edu.ua ²tennobi@yandex.ru

Abstract—In this paper a two-tier system for tracking critical parameters of hybrid power plants, such as generated power, generator current, rotational speed, and battery charge level is considered. The proposed system refers to the online display of the power usage of solar energy as a renewable energy. This paper describes an experimental investigation of wireless monitoring and control of smart microgrid prototype. Using Blynk cloud application its possible to track parameters of hybrid solar systems in real-time. The prototype can be implemented using different communication protocols based on technical requirements such as security, data rates, coverage area and type of application.

Index Terms—Renewable energy; IoT; wireless; communication; energy monitoring and control; hybrid renewable energy system, solar panels.

I. INTRODUCTION

Electricity is one of the most essential needs for humans in the present. Conversion of solar and wind energy into electricity does not only improve generation of electricity but also reduces pollution from fossil fuels. The output power of solar panel depends on solar irradiance, temperature and the load impedance. Hybrid power plants is one of the renewable energy sources used in present days technology. Photo voltaic (PV) has many benefits especially in environmental, economic and social aspects. In general, a PV system consists of a PV array, which converts sunlight to direct-current electricity, a control system that regulates battery charging, and the load [1]. A charge controller is one of functional and reliable major components in hybrid energy systems. A good, solid and reliable charge controller is a key component of any PV battery charging. The main function of a charge controller in a hybrid system is to regulate the voltage and current from PV solar panels and wind generator into a rechargeable battery. The minimum function of a charge controller is to disconnect the array when the battery is fully charged and keep the battery fully charged without damage. This goal is to ensure the batteries are working in optimal conditions, mainly to prevent overcharging (i.e. by disconnecting solar panel when batteries are full) and too deep discharge (by disconnecting the load when necessary). It also offers protection against the reverse current flow at night back to the PV. It has the advantage of adding microcontrollers Arduino and Raspberry Pi3 for readability of the voltage across the hybrid plant and, also the battery, this

work operates during day and/ or night, it has the advantage of connecting DC load on the system, simple and economically viable.

In nowadays there are exist such devices as micro-inverters and MPPT trackers, which can also track some parameters of solar panels. Micro-inverters are compact devices, easily combined and installed directly for each individual solar module, directly on the roof or on the structure. It also has a small MPPT tracker with incomplete functions inside it. The disadvantage of such inverters is the loss of power (during transportation to the battery or to another inverter to align current for the end user) and low resistance to the external environment, whether high humidity and cold, and such an inverter is not well maintained, which can affect on correct performance. It should be noted that the efficiency of microinverters is lower than that of the “traditional” ones. Therefore, when installing a large system (from a couple of kW), it makes sense to install an “adult” mains inverter, and here the “advantage” of the micro inverter is already lost. Well, at the end, for today one such micro-inverter will cost about \$300–600, which is quite a lot with a big amount of solar panels.

On the other hand, there is an available system covered in this paper. The succession of such a system:

- significantly reduced requirements for calculation and planning, installation costs, due to the modular design and low complexity;
- small installations for private electricity production, installed on the balcony or in the garden;
- standard Internet access ensures the ability to control the system at the level of a separate solar

panel. Its owner at any time has access to detailed analysis, diagnostics and performance monitoring via a smartphone or tablet.

This solar power system is designed to provide electricity to country houses, villas, small offices or shops, right up to urban development - apartments, townhouses and small architectural forms, that is, requires to get maximum energy, regardless of shade, roof configurations, architecture.

Each device is connected individually to each PV module in a common array of solar panels.

Such solar energy based on the best solutions for providing electricity from the sun country houses, townhouses, households with any architecture and design.

By applying such a solar energy supply system, each household owner decides for himself which scale it will be in scale, small or large. Depending on the need for energy, the possibilities of current or future financing, such a solar energy supply system can be gradually increased or rebuilt. Starting from the size of one solar panel, which can even be placed on a balcony, and further increase to several kilowatts; such a system has the ability to connect any number of additional modules.

Planning and design for the electrical part and installation of solar power systems is minimized. Regardless of where and how the solar panels will be installed, and installation, and installation, and the connection of this system is extremely simple.

The main objective of this work is to creation of monitor system using the current and voltage value sensed by Arduino. The monitoring of the hybrid solar energy system shows the power and energy usage using IoT [1], [2]. This system helps to implement in smart grid for efficient usage.

The developed prototype is designed for smart power system. The behavior of proposed system is wirelessly can be monitored by user

The proposed system relates to an online energy tracking system of hybrid power plants. This control is carried out through Raspberry Pi 3 using Arduino. Smart Monitoring displays the daily use of renewable energy sources: power control, maximum power points and efficient storage of stored energy. In this paper, an experimental study of wireless monitoring and control system prototype is described.

II. PROBLEM STATEMENT

The general task of this work is to create, based on the Arduino electronic platform, a universal instrument for collecting important data, then storing and processing information using Raspberry pi3 (Fig. 1). Also:

1) Determine the structure and parameters of the future system.

2) Definition of control parameters and selection of a set of technical means.

3) The choice of sensors, controllers for optimality of weight, size and cost.

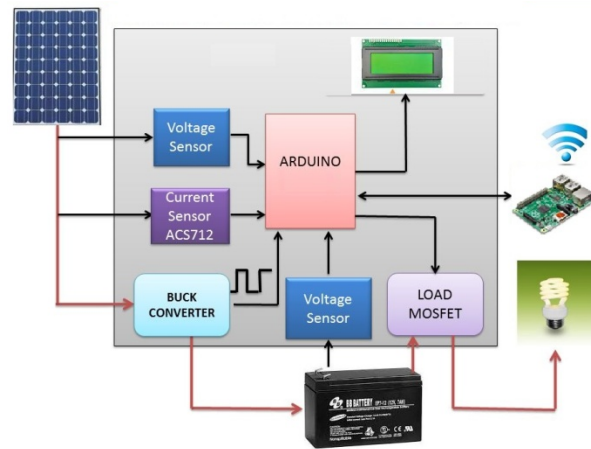

Fig. 1. System Design

When connecting to a computer using the browser, the screen should show the temperature, power, wind speed, generator power, generator voltage, battery charge level. Their values should be changed every 40 seconds.

III. RESEARCH METHOD AND SYSTEM DESIGN

Our task is to create an information system with minimal expense. This applies to both the total cost of the system and its minimum energy consumption. In practice, there are two concepts of creating a data acquisition device. The first concept – using simplified microcomputer systems that use the graphical programming language. The second – is based on the discrete elements, but requires high-level programming languages implementation. Between these two major concepts of creation such devices, there are intermediate solutions that combine small, inexpensive hardware modules and software in the form of "simplified" programming languages, which have much greater flexibility than graphic programming languages, but which do not require detailed studying the specifics of the architecture of specific families of microprocessors. One of the most successful representatives of such class of hardware and software platforms, in my opinion, is the Arduino platform. Given these approaches in designing hardware modules for data collection, it can be argued that the Arduino platform can be effectively used to address a variety of scientific and technical tasks, while significantly reducing time and cost of development. The Arduino platform is an easy-to-use open source platform that includes so-called starter kit and open source software. It is designed to quickly create interactive

electronic devices. Arduino is based on the Atmel Corporation's microcontroller and is used to receive signals from analog and digital sensors, control various actuators and exchange information with the computer through various interfaces. The Arduino platform simplifies the process of working with microcontrollers and allows to do simple projects even without soldering elements using the assembly of electromechanical connectors on the motherboard. At the same time, Arduino has several advantages over other devices. First, it's a low cost (some Arduino modules cost less than \$10). Secondly, the software for this platform runs on all the most common operating systems: Windows, iOS and Linux, while most other similar devices are limited to one system (either Windows or Linux). Thirdly, a simple and understandable programming environment. However, the problem is that for its use as a device for collecting data from analog and digital converters it is necessary to create software that would ensure the synchronization of the data acquisition device with a personal computer and allowed to display and record information from the primary converters.

For decision-making, for example, in the tasks of technical control of devices it is necessary to have information that can be obtained from sensors. The sensors can be located at a great distance from each other and from the control center [3]. Therefore, it can be used the Internet to access them.

For remote access to sensors it is possible to use microcontrollers or monoplane mini computers [4] – [6]. In this work, solving the task of accessing the sensors is considered single-payment mini-computers. Currently, the most popular and bought are Raspberry Pi 3, Banana Pi 2 and Orange Pi PC (Fig. 2).



Fig. 2. Single-board mini computers

These computers are united:

- small size, with a credit card;
- a quad-core processor that runs on all computers at approximately 1-1.2 GHz;
- 1 GB of RAM;
- SD card instead of a disk to load the operating system and programs;
- Ethernet port for connecting to the network;
- HDMI output for connecting a monitor or a TV;

- USB ports for connection, such as keyboards, mice, flash memory;
- operating system Linux;
- and most importantly – the 40-pin GPIO port to which devices are connected, sensors that need to be controlled.

The main task is to choose a computer for remote control.

1) Cost (on 09/25/2018, the site <http://aliexpress.com> with delivery):

- Raspberry Pi 3 – \$ 36.99;
- Banana Pi 2 (BPI-M2 A31S) – \$ 50.21;
- Orange Pi pc – \$ 18.99;
- Asus Tinker Board – \$86.88.

2) Processor Speed + Memory. For computational tests using 4 cores:

- Banana Pi 2 (BPI-M2 A31S);
- Orange Pi PC;
- Raspberry Pi 3.

When using one core for computing (the task is not parallelized):

- Orange Pi PC;
- Banana Pi 2 (BPI-M2 A31S);
- Raspberry Pi 3.

Note that Orange Pi runs 3 cores, and the fourth does not always start.

Also, Orange Pi PC does not have yet a prerequisite for device management – it's software support for the GPIO port.

3) Remote control of sensors and devices can be performed using microcontrollers:

- Arduino Mega256 with Ethernet Shield w5100 – \$ 12-15;
- Arduino nano with network controller enc28j60 – \$ 8-9;
- ESP8266-12 – \$ 2-3.

Experience has shown that microcontrollers work well on the local network, with the loss of control packets in the global network becomes unreliable. Minicomputers operate under the Linux operating system, in which network protocols are well established. It can be made with a high degree of protection to enter the managed system. Microcontrollers have not enough resources for good protocols and hacking protection.

Based on the above, for remote sensor operation, the Mini-computer Raspberry Pi 3 is used. The task must be solved:

- When connecting to a computer using the browser, the screen should display the temperature, power, wind speed, generator power, generator voltage, battery level. Their values should be changed every 15 seconds.

– The script must record the pressure and temperature in the files every 5 minutes. They are used to construct graphs.

– It is necessary to provide remote control of the device. Just only required connection to the Internet, for example, through a Wi-Fi or through an Ethernet port.

The main unit of the system will consist of two subsystems. The upper level of the subsystem will be represented by a Raspberry Pi 3 B microcomputer with the General Purpose I/O Interface (GPIO) interface for interfacing with lower-level subsystems. This system will be responsible for data analysis, the user interface for mobile devices, decision making, data storage, remote access (mainly through SSH). The power of the system will come directly from the panels, because it uses a 12 V DC power supply. The code will be implemented in Python and with Lua scripts.

The lower level of the system will include the Arduino base (Nano or Micro). Arduino was chosen due to its rapid collection of analog data, but Raspberry needs a decent amount of time to analyze the input data. In addition, the interaction with analogue data from the source is less severe than that of Raspberry.

To measure the voltage, we will use Arduino with a voltage divider. The idea of using a voltage divider came from the fact that Arduino can be measured only up to 5 V DC and its can not be used for photovoltaic cells, in order to get around this, it can be used a voltage divider that will allow us to use Arduino to power up.

Voltage dividers can be used to allow a microcontroller to measure the resistance of a sensor. The sensor is wired in series with a known resistance to form a voltage divider and a known voltage is applied across the divider. The microcontroller's analog-to-digital converter is connected to the center tap of the divider so that it can measure the tap voltage and, by using the measured voltage and the known resistance and voltage, compute the sensor resistance. An example that is commonly used involves a potentiometer (variable resistor) as one of the resistive elements. When the shaft of the potentiometer is rotated the resistance it produces either increases or decreases, the change in resistance corresponds to the angular change of the shaft. If coupled with a stable voltage reference, the output voltage can be fed into an analog-to-digital converter and a display can show the angle. Such circuits are commonly used in reading control knobs.

High voltage measurement. A voltage divider can be used to scale down a very high voltage so that it can be measured by a volt meter. The high voltage

is applied across the divider, and the divider output—which outputs a lower voltage that is within the meter's input range—is measured by the meter. High voltage resistor divider probes designed specifically for this purpose can be used to measure voltages up to 100 kV. Special high-voltage resistors are used in such probes as they must be able to tolerate high input voltages and, to produce accurate results, must have matched temperature coefficients and very low voltage coefficients. Capacitive divider probes are typically used for voltages above 100 kV, as the heat caused by power losses in resistor divider probes at such high voltages could be excessive.

DC Voltage using Arduino. Arduino analog inputs can be used to measure DC voltage between 0 and 5 V (on 5 V Arduinos such as the Arduino Uno when using the standard 5 V analog reference voltage).

The range over which the Arduino can measure voltage can be increased by using two resistors to create a voltage divider. The voltage divider decreases the voltage being measured to within the range of the Arduino analog inputs. Code in the Arduino sketch is then used to calculate the actual voltage being measured.

This allows voltages greater than 5 V to be measured.

Voltage Divider Circuit. A voltage divider circuit consisting of two resistors in series will divide the input voltage within the range of the Arduino analog inputs.

The circuit shown below will divide the input voltage by 11 (from the battery as the example input voltage being measured).

The circuit with the particular values shown has an input impedance of $100\text{ M}\Omega + 500\text{ k}\Omega = 100.5\text{ M}\Omega$ and is suitable for measuring DC voltages up to about 1500 V.

Input Protection. The resistor values in the circuit diagram above provide some over-voltage protection when measuring low voltages such as 5 V, 9 V or 12 V. So if a voltage of say 30 V is accidentally measured, it will not blow the Arduino analog input pin.

Any voltage higher than about 1000 V could damage the Arduino. The point on the resistor divider network connected to the Arduino analog pin is equivalent to the input voltage divided by 200, so $1000\text{ V} \dots 200 = 5\text{ V}$. In other words, when measuring 1000 V, the Arduino analog pin will be at its maximum voltage of 5 V.

Providing this basic over-voltage protection is at the expense of not using the full 10-bit range of the analog input ADC if only lower voltages are to be measured, but changes of about 0.054 V can still be measured.

IV. SELECTION OF A SET OF TECHNICAL MEANS

For optimal selection of control boards, we will obtain it by algorithm for hierarchy analysis method [4]. The hierarchy analysis method includes the following steps:

1) Structuring the task in the form of a hierarchical structure with several levels: goal – criterion – alternatives.

2) Assessment of the decisions made performs paired comparison of elements of each level. The results of the comparisons are interpreted into quantitative estimates using the appropriate scale.

3) Calculate the importance factors for the elements of each level. At the same time, the consistency of the reasons for evaluating the decisions taken is checked.

4) The quantitative indicator of the quality of each of the alternatives is calculated and the best alternative is determined.

Applying the hierarchy analysis method to the task.

A. Structuring the task

The solvable problem can be represented as a hierarchical structure represented in Fig. 3.

B. Pair comparison

In paired comparisons, an assessment of the decisions taken at the disposal of the decision is given a scale of verbal definitions of the importance level, with each definition is put in correspondence with the number (Table I).

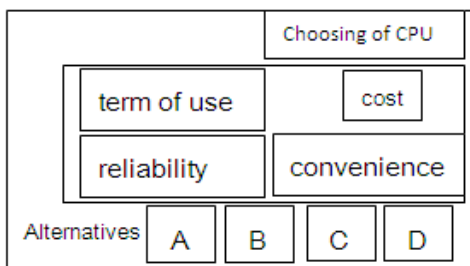

Fig. 3. Hierarchical scheme of the problem of CPU choice

When comparing elements belonging to the same level of the hierarchy, the assessment of the

decisions made expresses its opinion, using one of the definitions given in Table I. The matrix of comparison corresponds to the number. The matrix of comparisons of the selection criteria of the control system is shown in the Table III.

TABLE I SCALE OF COMPARISONS OF ALTERNATIVES AND CRITERIA

Level of importance	Quantitative value
Equal importance	1
Moderate advantage	3
Significant or strong advantage	5
Significant (big) advantage	7
Very great advantage	9

The matrix corresponds to the following advantages of the assessment of the decisions the criterion "Cost" significantly exceeds the criterion "Term of use" and moderately exceeds the criterion "Reliability"; the criterion "Term of use" moderately deflects the "Reliability" criterion. Moreover, the "convenience" criterion has a moderate advantage over almost all parameters. At the lower level of the hierarchical scheme, the given alternatives are compared, and each criterion is separate.

C. Calculation of importance factors

Tables II and III allow calculating the coefficients of importance of the corresponding elements of the hierarchical level. To do this, required calculation of positive vectors of the matrix, and then normalize them. The formula for these calculations: extracts the root n th degree (n -dimensional matrix of comparisons) from the product of the elements of each line.

D. Definition of the best alternative

Synthesis of the obtained coefficients of importance is carried out according to the formula

$$S_j = \sum_{i=1}^n w_i V_{ij},$$

where S_j is the quality of j -alternative; w_i is the weight of i th criteria; V_{ij} is the importance of j -alternative on the i th criterion.

TABLE II. MATRIX OF COMPARISONS FOR CRITERIA

	cost	reliability	term	conv.	vector	weight
cost	1.00	4.00	6.00	0.50	1.86	0.39
reliability	0.25	1.00	2.00	1.00	0.84	0.17
term	0.17	0.50	1.00	0.25	0.37	0.07
conv.	2.00	1.00	4.00	1.00	1.68	0.35
sum					4.76	

TABLE III. RELATIVE IMPORTANCE OF ALTERNATIVES ACCORDING TO INDIVIDUAL CRITERIA (COST, RELIABILITY, TERM OF USE, CONVENIENCE)

	Tinker	Banana	Rasp.Pi 3	Orange	vector	weight
Tinker	1.00	0.33	0.14	0.11	0.27	0.04
Banana	3.00	1.00	0.33	0.14	0.61	0.10
Rasp.Pi 3	7.00	3.00	1.00	0.50	1.80	0.30
Orange	9.00	7.00	2.00	1.00	3.35	0.56
					6.03	1.00
	Tinker	Banana	Rasp.Pi 3	Orange	vector	weight
Tinker	1.00	5.00	3.00	9.00	3.41	0.55
Banana	0.20	1.00	0.20	5.00	0.67	0.11
Rasp.Pi 3	0.33	5.00	1.00	7.00	1.85	0.30
Orange	0.11	0.14	0.14	1.00	0.22	0.04
					6.14	
	Tinker	Banana	Rasp.Pi 3	Orange	vector	weight
Tinker	1.00	0.50	5.00	7.00	2.05	0.34
Banana	2.00	1.00	4.00	9.00	2.91	0.49
Rasp.Pi 3	0.20	0.25	1.00	5.00	0.71	0.12
Orange	0.14	0.11	0.33	1.00	0.27	0.05
					5.94	
	Tinker	Banana	Rasp.Pi 3	Orange	vector	weight
Tinker	1.00	6.00	1.00	9.00	2.71	0.569
Banana	0.17	1.00	0.20	7.00	0.69	0.145
Rasp.Pi 3	1.00	5.00	1.00	7.00	2.43	0.510
Orange	0.11	0.14	0.14	1.00	0.218	0.045
					6.06	

For the four alternatives, the following calculations are performed:

$$S(A) = 0.39 \cdot 0.04 + 0.176 \cdot 0.11 + 0.079 \cdot 0.34 + 0.35 \cdot 0.56 = 0.343769308,$$

$$S(B) = 0.39 \cdot 0.10 + 0.176 \cdot 0.11 + 0.079 \cdot 0.49 + 0.353 + 0.145894 = 0.149662164,$$

$$S(C) = 0.39 \cdot 0.30 + 0.176 \cdot 0.30 + 0.0797 \cdot 0.30 + 0.3530 + 0.5105 = 0.359389431,$$

$$S(D) = 0.3906 \cdot 0.56 + 0.176 \cdot 0.04 + 0.07975 \cdot 0.05 + 0.35 \cdot 0.046 = 0.242964677,$$

where A is the Asus Tinker Board; B is the Banana Pi; C is the RaspberryPi 3; D is the Orange Pi.

So, alternative C according to the preference for evaluating the decisions made is the best.

V. RESULTS

Using Blynk cloud application we can tracking our parameners in real-time (Fig. 4).

This system basically monitors a simple charge controller that is fed from a couple of solar panels wired in parallel. The App runs 24/7 and gives me updates on charge rate, battery voltage, outside temperature and a history graph of the whole thing so i can look back a recollect how sunny it was.

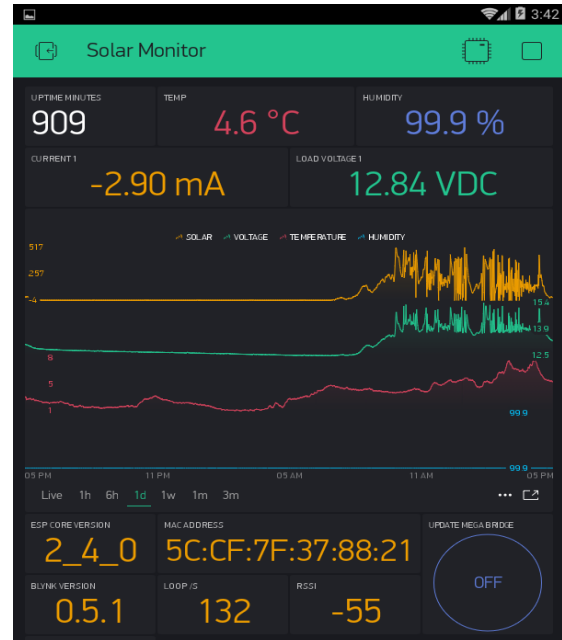

Fig. 4. Our solar tracking system with Blynk cloud application

VI. CONCLUSIONS

In this work, the system for tracking parameters of the hybrid installations, using the Raspberry Pi 3 and Arduino microcontrollers with current and voltage sensors, was developed and built.

Experimental results give real-time monitoring of data from all the input sensors that are interfaced with Arduino and Raspberry Pi 3. By using this system we get real-time monitoring of hybrid solar energy system. Different environmental parameters are monitored by using different sensors. Such important parameters as generated power, generator current, rotational speed, and battery charge level and power usage can be observed. Real-time data from embedded web server which using Raspberry Pi can be obtained. This system gives fast data transfer. It has good performance ability and low power consumption.

Implementing Renewable Energy technologies is one recommended way of reducing the environmental impact. Because of the frequent reduction in power, it is important to use renewable energy and track it. Tracking guides the user in analysis of renewable energy usage. This system is cost effective and proposed design uses low power communication protocol. This enables the efficient use of renewable energy. Thus, it is reducing the electricity issues.

The prototype can be implemented using different communication protocols based on technical requirements such as security, data rates, coverage area and type of application. Future work includes development of energy tracking and control system for industrial network applications. The web application can be developed for interaction with the end user; the user can also predict values of the future events. In the same way, android application can be developed also.

REFERENCES

- [1] M. Kovalcik, P. Fecilak, and F. Jakab, "Control and monitoring system of small water and wind power plant," *Emerging eLearning Technologies and Applications (ICETA), 2013 IEEE 11th International Conference*, 2013, pp. 235–238.
- [2] A. C. D. Bonganay et al., "Automated electric meter reading and monitoring system using ZigBee-integrated raspberry Pi single board computer via Modbus," *Electrical, Electronics and Computer Science (SCEECS), 2014 IEEE Students' Conference on IEEE*, 2014, pp. 1–6.
- [3] Prof. Satyashil Nagrale, Ms. Poonam Khetmalis, Sanika Doke, and Varsha Dherange, "Real Time Data Transmission for Weather Monitoring System," *International Research Journal of Engineering and Technology (IRJET)*, vol. 03, Issue 02, Feb 2016.
- [4] S. Ferdoush and X. Li, "Wireless sensor network system design using Raspberry Pi and Arduino for environmental monitoring applications," *Procedia Computer Science*. vol. 34, pp. 103–110, 2014.
- [5] . D. N. Mazurov, "Research and development of client-server information and control distance learning system based on the Raspberry Pi 2 microcomputer," *All-Russian Scientific Conference on Control Problems in Technical Systems*. Federal State Autonomous Educational Institution of Higher Education St. Petersburg state electrotechnical university «LETI» of V. I. Ulyanov (Lenin), no. 1, 2015, pp. 377–379. (in Russian)
- [6] V. Vujovic and M. Maksimovic, "Raspberry Pi as a Sensor Web node for home automation," *Computers & Electrical Engineering*, vol. 44, pp. 153–171, 2015.

Received March 14, 2018

Sineglazov Victor. Doctor of Engineering Science. Professor. Head of the Department.

Aviation Computer-Integrated Complexes Department, Education&Scientific Institute of Information-Diagnostics Systems, National Aviation University, Kyiv, Ukraine.

Education: Kyiv Polytechnic Institute, Kyiv, Ukraine, (1973).

Research area: Air Navigation, Air Traffic Control, Identification of Complex Systems, Wind/Solar power plant.

Publications: more than 600 papers.

E-mail: svm@nau.edu.ua

Kopaniev Vladislav. Master.

Aviation Computer-Integrated Complexes Department, Education&Scientific Institute of Information-Diagnostics Systems, National Aviation University, Kyiv, Ukraine.

Education: National Aviation University, Kyiv, Ukraine, (2017).

Research interests: Automatic control systems, Applied Mathematics, Wind/Solar power plant.

Publications: 8.

E-mail: tennobi@yandex.ru

В. М. Синеглазов, В. О. Копанєв Інформаційна система для вимірювання, передавання та оброблення параметрів гібридних енергоустановок

У статті розглянуто дворівневу систему для відстеження важливих параметрів гібридних енергоустановок, таких як генерується потужність, струм генератора, швидкість обертання і заряд батареї. Запропонована система відображає в режимі он-лайн моніторинг використання сонячної енергії як джерела відновлюваної енергії. В роботі описано експериментальне дослідження системи бездротового моніторингу та керування

прототипом розумних мікромереж. Використовуючи хмарний сервіс з IoT Blynk з'являється можливість для відстеження параметрів гібридних енергоустановок в режимі реального часу. Прототип можна реалізувати використовуючи різні протоколи з'єднання, що засновані на технічних вимогах, таких як безпека, швидкість передачі даних, зона покриття та тип програми.

Ключові слова: поновлювана енергетика; IoT; бездротові технології; відстеження і керування енергією; гібридні енергоустановки; сонячні панелі.

Синеглазов Віктор Михайлович. Доктор технічних наук. Професор. Зав. кафедри.

Кафедра авіаційних комп'ютерно-інтегрованих комплексів, Навчально-науковий інститут інформаційно-діагностичних систем, Національний авіаційний університет, Київ, Україна.

Освіта: Київський політехнічний інститут, Київ, Україна, (1973).

Напрямок наукової діяльності: аеронавігація, управління повітряним рухом, ідентифікація складних систем, вітроенергетичні установки.

Кількість публікацій: більше 600 наукових робіт.

E-mail: svm@nau.edu.ua

Копанев Владислав Олександрович. Магістр.

Кафедра авіаційних комп'ютерно-інтегрованих комплексів, Навчально-науковий інститут інформаційно-діагностичних систем, Національний авіаційний університет, Київ, Україна.

Освіта: Національний авіаційний університет, Київ, Україна, (2017).

Напрямок наукової діяльності: автоматичні системи управління, прикладна математика, вітроенергетичні установки.

Кількість публікацій: 8.

E-mail: tennobi@yandex.ru

В. М. Синеглазов, В. А. Копанев. Информационная система для измерения, передачи и обработки параметров гибридных энергоустановок

В статье рассмотрена двухуровневая система для отслеживания важных параметров гибридных энергоустановок, таких как генерируемая мощность, ток генератора, скорость вращения и заряд батареи. Предлагаемая система отображает в режиме он-лайн мониторинг использования солнечной энергии как источника возобновляемой энергии. В работе описано экспериментальное исследование системы беспроводного мониторинга и управление прототипом умных микросетей. Использую облачный сервис с IoT Blynk появляется возможность для отслеживания параметров гибридных энергоустановок в режиме реального времени. Прототип может быть реализован с использованием различных протоколов соединения, основанных на технических требованиях, таких как безопасность, скорость передачи данных, зона покрытия и тип приложения.

Ключевые слова: возобновляемая энергетика; IoT; беспроводные технологии; отслеживание и управление энергией; гибридные энергоустановки; солнечные панели.

Синеглазов Виктор Михайлович. Доктор технических наук. Профессор. Зав. кафедры.

Кафедра авиационных компьютерно-интегрированных комплексов, Учебно-научный институт информационно-диагностических систем, Национальный авиационный университет, Киев, Украина.

Образование: Киевский политехнический институт, Киев, Украина, (1973).

Направление научной деятельности: аэронавигация, управление воздушным движением, идентификация сложных систем, ветроэнергетические установки.

Количество публикаций: более 600 научных работ.

E-mail: svm@nau.edu.ua

Копанев Владислав Александрович. Магистр.

Кафедра авиационных компьютерно-интегрированных комплексов, Учебно-научный институт информационно-диагностических систем, Национальный авиационный университет, Киев, Украина.

Образование: Национальный авиационный университет, Киев, Украина, (2017).

Направление научной деятельности: автоматические системы управления, прикладная математика, ветроэнергетические установки.

Количество публикаций: 8.

E-mail: tennobi@yandex.ru