

UDC 629.4.013.22:629.735 “712” (045)

DOI: 10.18372/1990-5548.56.12932

¹A. P. Kozlov,
²L. S. Gladka**HIGH-PRECISION ONBOARD FUEL LEVEL CONTROL AND MEASUREMENT SYSTEM**

^{1,2}Aviation Computer-Integrated Complexes Department, Educational&Scientific Institute of Information-Diagnostics Systems, National Aviation University, Kyiv, Ukraine
E-mails: ¹ap_kozlov@ukr.net, ²mila.gladka.26@gmail.com

Abstract—The fueling systems of modern aircraft are considered. The need for their further improvement is shown in accordance with the recommendations of ICAO. A brief overview of methods and means of measuring fuel level in tanks in modern aviation fuel meters are given. It is proposed to develop and create high-precision air flowmeters and to develop a structure based on the measurement of the cost of fuel oil in tanks with automatic stabilization of air pressure in the tank. The designs of the diaphragm knot and the differential pressure gauge included in the volumetric fueling system are considered. The developed system allows to create equipment with the improved characteristics.

Index Terms—Fuel metering system; level gauges; aviation fuel gauges; volumetric method; diaphragm knot; differential pressure gauge; tank-caisson.

I. INTRODUCTION

At the present time due to the increased requirements to ensure the safety, cost of transportation, reducing the complexity and cost of servicing fuel log systems (FLS) was necessary to improve their accuracy characteristics, as the main reserve aircraft weight is to reduce the weight of the transported fuel that fueled more than necessary for flight.

For years, airlines have specific internal difficulties caused by the work of the FLS. The nature of the system provokes a situation of failure, which should be removed before flight. It is typical fact that the refusal is difficult to eliminate and it is required a considerable amount of time to isolate the fault and correct it.

Systems which installed on airplanes are characterized by a large number of failures during the flight, and it is very difficult to simulate them on the ground. This leads to a lot of failures in search of malfunctions and thousands of man-hours spent not reproductively. For a list of the complexity of the problems head problems associated with wiring. The complexity of these problems is due to size, confusion (complexity) and the route of the wiring. Problems in this area are caused by the sensitivity of the system to violations of ground shielded cables. Replacing wiring can take 30 hours, and sometimes days. Most have replaced all the wiring through failure in the chain of a single cable.

In the operation of the existing FLS accumulated a sufficient number of statistical analysis which leads carefully view of existing systems and their substantial modernization in order to improve the accuracy, reliability, maintainability, simplified main-

tenance, etc. On the other hand modern equipment receives at their disposal very powerful hardware, advanced manufacturing technology technical means, the use of composite materials. All this combined can solve the problem of exploitation of FLS.

Known localized acoustic equilibria, in which the current position of the liquid level is determined by the time the ultrasonic vibrations pass from the source to the receiver when reflected from the separation surface of the two media. To the disadvantages of the location gauge, first of all, it is necessary to relate the requirements of a certain mutual position of the emitter-receiver and the surface of the reflecting level, which ensures the arrival of the signal to the receiver. Perturbation of the surface of the fuel will result in the reflected signal not getting to the receiver or will be very weakened. In addition, various levels of fuel consumption (especially gas bubbles) and the change in sound speed in fuel, depending on the variety and density, are affected by the measurement error. Compensation for these errors significantly complicates the measurement scheme and is not always very effective.

In radioisotope levels, the effect of absorption of nuclear radiation by the atoms of a substance (fuel) is used, and it is proportional to the density of a substance, that is, the method is based on the use of the difference in the density of substances forming the boundary of the section. In most radioisotope levels, isotopes of Cobalt-60 or Cesium-137 are used.

The current state of aviation technology, implementation of computational tools in aviation equipment, and increased demands on the efficiency of flights structures require review of aviation

equipment and increasing requirements for the most important parameters of aircraft systems. This primarily relates to fuel log systems. The documents are ICAO recommendations for further improvement FLS current and future aircraft. A brief analysis of operating experience at present FLS shows that the level of reliability, error, maintenance costs require further improvement.

The reasons for the disappointing results of existing power capacitive level gauges are:

- significant influence of moisture in the fuel;
- a significant number of wiring that is exposed to external influences;
- complicated intra tank equipment that requires a significant investment of time for maintenance;
- dependence between the indication sensors on the spatial position of the aircraft and others.

Also there are ways of further improving the FLS and recommendations on the development of FLS based volume metric method in ICAO materials. This method can be implemented in two variants.

The first variant is measuring fuel consumption and integrating the results of measurements to obtain estimates of volume. However, due to the fact that the range of measured values is quite heterogeneous, and results measurement depends on the type of fuel and its temperature, this method can be implemented only at the account of these influences and effective means of correction.

The second variant is measurement of over the fuel air at stabilizing its pressure in the tank corresponding system of automatic stabilization of pressure. This method was not implemented due to lack of precision measuring air flow. Development of hardware flow measurement precision by using special designs and test circuits that include computing, let do this development.

The basis for the implementation of this development:

- developments in the field of precision measurements of small quantities of capacity by means of transformer bridges;
- developments in the field of micro displacement measurement using capacitive sensors;
- a wide range of schemo-technical solutions of microprocessor systems.

II. PROBLEM STATEMENT

The purpose of modeling is to obtain the transformation function of capacitive converter, the study of factors affecting, and finding ways to achieve the desired type of transformation function. This problem is reduced to calculations of electrostatic induction flows, namely to calculate change of the value of capacitance in function.

Proposed the following approach to the solving the problem of modeling the electromagnetic field of capacitive transducer. Between the charges and potentials of conductors of any interaction there is a clear linear relationship to the expression of which introduces the concept of electric capacity. There are separate capacity of the conductor capacitance between two conductors and capacity in system of many leaders.

III. PROBLEM SOLUTION

In order to find ways to solve the problem, a review and analysis of existing flow meters was conducted. The flowmeter is divided, as a rule, into four types according to the principle of action: electromagnetic, ultrasonic, vortical and mechanical [3].

The principle of action of electromagnetic flowmeter is based on the ability of the measured liquid to excite an electric current in its motion in a magnetic field. Since there are small quantities of current, these devices are very sensitive to the quality of installation, conditions of operation. Insufficient high-quality wiring, the appearance of additional resistance in the joints, the presence of impurities in water dramatically increase the error of device displays.

Ultrasound counters operate on the principle of changing the time interval of the passage of the ultrasound signal from the source to the receiver of signals, which depends on the flow rate of the liquid. These devices work well when measuring the flow of clean, homogeneous liquid through clean pipes.

The vortex flowmeters operate on the principle of a vortex "Karman track" formed by a plate. Failure of the flow of flow causes fluctuations in the pressure, the measurement of which allows to determine the volume of fluid flowing through the pipeline. Devices of this type are also sensitive to abrupt changes in the flow of fluid, to the presence of large impurities.

The principle of the operation of mechanical flowmeters (turbine, turbine, screw) is based on the transformation of the translational flow of the fluid into the rotating motion of the measuring part. These are the simplest devices. These flowmeters are largely devoid of defects inherent in electromagnetic and ultrasonic flowmeters.

In our opinion, the most suitable solution to the problem is the flowmeter variable pressure difference.

The principle of the flow meters of AC differential pressure based on measurements of pressure drop, formed as a result of local changes in air velocity.

For the measurement of consumption of the liquids in the pressure drop required three elements:

1) a device that creates a pressure drop in the flow of the measured medium by local flow velocity changes in magnitude (narrowing device) or direction (curved pipe section);

2) gauge – differential manometer that measures the pressure difference;

3) a connecting device that transmits pressure drop of the flow to the differential manometer.

Proceeding from the foregoing, the construction of elements of the diaphragm air flow meter was developed, the pressure difference being measured using a differential pressure gauge.

By measuring the pressure difference at the intersection I-I before the diaphragm, where the flow does not change its configuration, and II-II in the place of the greatest compression of the flow, determine the flow of air in the pipeline. In the general form, we have the dependence $Q = kF(p_2 - p_1)$. The coefficient k depends on the diameter of the pipeline and the size of the flat diaphragm [1].

The design of the differential meter is constructed of two types of one-type nodes mechanically connected to each other, and a differential capacitive displacement sensor (Fig. 1).

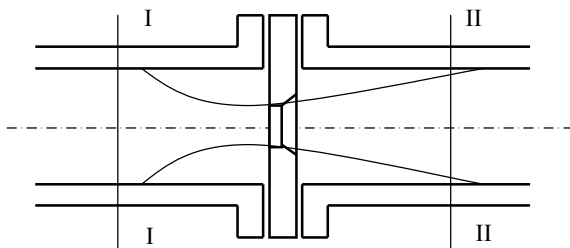

Fig. 1. Construction of the diaphragm node

To ensure the increased accuracy of the measurement of pressure difference, special requirements are imposed on the difmonometer's design. Any displacements of elastic elements during operation must be excluded, good linearity of the characteristics in the operating range must be ensured, the temperature errors must be constructively reduced to a minimum, the structure must not collapse or fail in the case of a sharp one-sided pressure drop, the following should be provided: necessary tightness of receiving chambers, isolation of electric power units is necessary, adjustment of "zero" is possible, simple disassembly (for washing or cleaning) and assembly at service and no repair.

As can be seen from the figure completely, symmetrical design, except for elements 4, 5 connecting the two symmetrical nodes. Each node consists of an elastic element 2, the cover 1, the

housing receiving of chamber 11, the locking stop 13, the nut 10, sealing elements 9 and 12, and high-low potential electrode of capacitive convertor 7, the insulators 6, 8, 15, and the screen 3 [4].

IV. DEVELOPMENT OF DESIGNS OF DIAPHRAGM KNOT AND DIFMANOMETER

The basis of the method for measuring the flow rate under pressure is the application of a flat diaphragm placed in the pipeline (see Fig. 1). Parameters and the shape of the air flow passing through the diaphragm in the process of movement along the pipeline are changing.

Movable grounded electrode of capacitive convertor consists of a sleeve 4 and two regulating screws 5.

Elastic element 2 is a body- nubbin of rectangular shape with rounded corners, which have 4 threaded holes to connect the two nodes of differential manometer, twoplanar circular membranes and two cylinders to connect the body and membranes in single node. This detail is made from one piece of metal on a mandrel turning, as the membrane thickness of 0.3 mm, followed by quenching to obtain required hardness.

This design of the elastic unit eliminates any radial displacements of membranes during operation. Widely used strong fixing of membranes lead to the fact that static characteristic elastic element floats in service. Production of planar or even ruffled by stamping naturally cheaper but high precision of elastic node can't be achieved. Recently, for fixing the membrane in the body often argon or hydrogen electric is used, but in the process of welding material structure is broken, it is not possible to obtain a homogeneous and identical from sample to sample elasticity. The proposed design is free of these drawbacks, because the elastic elements are made of one piece and subjected to hardening in a heat chamber in a given mode. In the case of steel, hardening is not required, which further increases the likelihood of obtaining identical in elastic elements.

The cover 1 and elastic element 2 are connected by soldering to ensure tightness. The hole in the cover 1 to access the adjusting screw is sealed by nut 10 with sealing gasket 9. For better tightness in the face of the carving hub the cover is collar of triangular section. A similar groove is the relevant part of nut. The body 11 screwed on the elastic element with which forms the receiving chamber. At the bottom of the body 11 is tap nozzle to connect pipeline of supply pressure.

Hermetic sealing is provided by a ring-gasket 12 and the protrusion with groove on the body 11.

The gate 13 serves to prevent the destruction of the elastic element with a sudden change in pressure in the chamber.

Electro capacitive converter consists of two pairs of electrodes 7, form two capacitors with non-uniform field, and the sleeve 4, which moves under the influence of pressure difference in the receiving cells differentially measures the size of containers left and right capacitors. Operating movement of the selected order 0.08–0.1 mm is for linearity performance. Placement of a mobile hub symmetrically relatively reception camera provides good temperature resistance because of temperature resizing of foster cameras symmetric with position on the mobile hub. Adjusting screws 5 screwed into the sleeve 4 and tightly fixed tight tightening. Screws are used to adjust "mechanical zero", i.e. equality of capacities in the absence of pressure in the chambers. The design of electrodes and regulating elements are useful and reliable in the assembly and operation. Electrical outputs from the electrodes still, do not require sealing. The probability of leakage of the measured areas of the electronic manometer completely excluded.

Assemblage of nodes manometer screw driving is performed by a mobile unit (5–4–5) in the elastic element, then screwed the second elastic element to the first osculation. Fixing holes in buildings nubbin-2 does not match, so do additional turn of elastic elements 2 relative to each other to match fixing holes. Thus reached a preliminary tension of

the membranes that provides improved of linearity characteristics in the values Δp , close to zero, and reducing of a hysteresis of membranes. The collected part is included in the measurement circuit being completed "zero" nut 10 is sealed, then welling buildings of foster chambers and nozzles lead to measurable pressure pipelines. (Fig. 2).

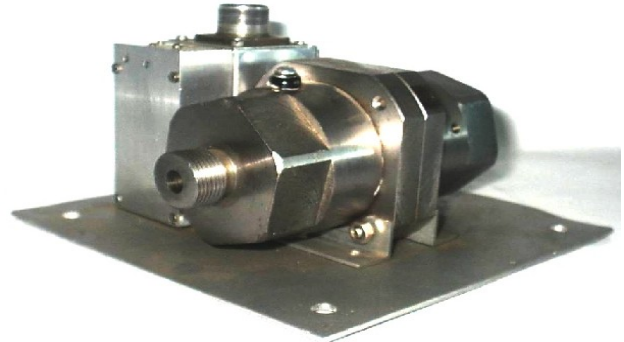

Fig. 2. The exterior differential manometer

V. DEVELOPMENT AND DESCRIPTION OF THE BLOCK DIAGRAM OF A FUEL METERING SYSTEM

Based on the analysis of domestic and imported fuel measures, review of technical information in the field of level measurement and the number of liquid environments in tanks, studying the experience of operating the fuel log systems (FLS) and requirements to the modern plant, developed a block diagram of a digital fuel level sensor in the tank perspective aircraft. The block diagram shown in Fig. 3.

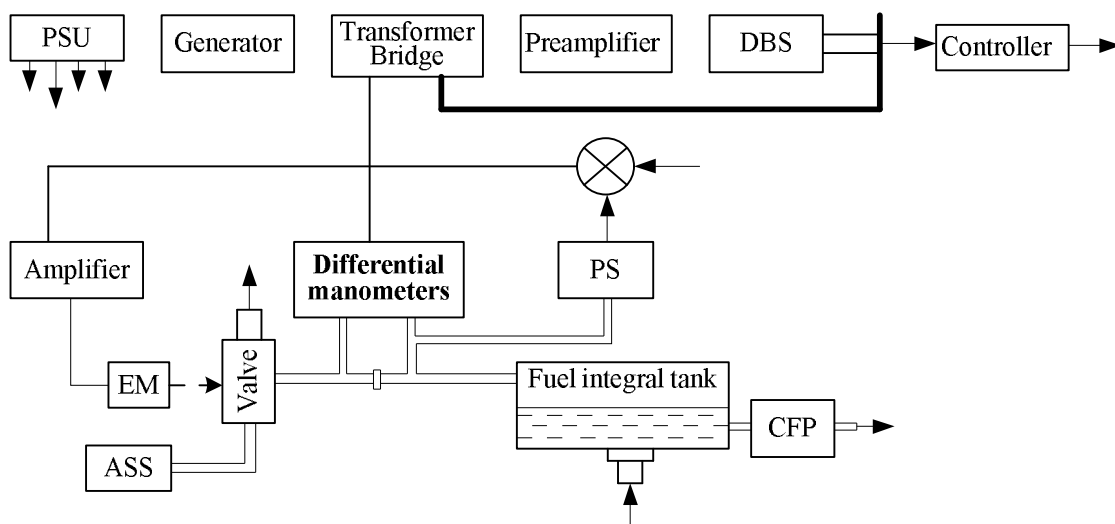

Fig. 3. The block diagram of differential manometer

The scheme works as follows: When the bridge imbalance signal is fed to an amplifier. With the amplifier signal is fed to two comparators. Depending on the sign of the output of one of the comparators signal logical unit appears. With

electronic key, the counter is set direction account. The same signal is sent to the logic circuit "AND-NO" and authorizes clock generator apply pulses to the counting input. Discharges meters consistently filled. The output of each of the discharge means

electronic key whose function is connection to the transformer windings shoulder bridge. The process continues until the bridge come into balance and the output signal the bridge will be less than the limit value comparator. Formed at the output of the counter code and transmitted to the controller, which is converted into a serial. Launching the scheme to measure and read the result produced the commands of CPU, the transmission signal of which generated by currents loop. In the presence of fuel that appears during centripetal fuel pump (CFP), the air pressure in the tank decreases. Reducing fixed pressure sensor and signal unbalance between the measured pressure and preset triggers block electromagnetic (EM), which opens the valve for the air supply system of air supply (ASS). This manometer measures the flow of supplied air again measured via the measuring part. The scheme works similarly, except that the logical unit mark appears at the output of the second comparator and an electronic key signals change the score.

VI. CONCLUSION

In the developed volumetric fuel metering system will significantly improve the performance of aircraft equipment. This is due to the fact that FLS is present in inbore equipment. The use of capacitive transducers in a differential manometer allows to

measure small displacements of elastic elements, which makes it possible to obtain a linear static characteristic of the device. The purpose-metal construction of elastic elements and their interlacement compensates for the effect of changes in temperature and air. The results of experimental studies of the developed micro-displacement sensor showed the high sensitivity of the capacitive transducers with the "open" field. The application of a fuel metering system based on a volumetric principle is perspective.

REFERENCES

- [1] G. N. Bobrovnikov and A. G. Katkov, *Methods for measuring levels*. Moscow, Mashinostroenie, 1977, 168 p. (in Russian)
- [2] O. A. Kuznetsov, *Automatic level control of two media*, Leningrad, Energia, 1984, 88 p. (in Russian)
- [3] S. F. Chistyakov and D. V. Radun, *Thermotechnical measurements and instruments*. Moscow, Vysshaya shkola, 1972, 392 p. (in Russian)
- [4] A. V. Bugrov, *High-frequency capacitive converters and quality control devices*. Moscow, Mashinostroenie, 1982, 96 p. (in Russian).

Received January 18, 2018

Anatoliy Kozlov. Candidate of Science (Engineering). Assistant Professor.

Aviation Computer-Integrated Complexes Department, Education & Scientific Institute of Information-Diagnostics Systems, National Aviation University, Kyiv, Ukraine.

Education: Kyiv State University named after T. G. Shevchenko, Kyiv, Ukraine, (1965).

Research area: Capacitive Transducers with an Inhomogeneous Magnetic Field, Technological Measurements, Aviation Devices and Information Systems, Automation Systems Design.

Publications: more than 50 papers.

E-mail: ap_kozlov@ukr.net

Lyuda Gladka. Master.

Aviation Computer-Integrated Complexes Department, Education&Scientific Institute of Information-Diagnostics Systems, National Aviation University, Kyiv, Ukraine.

Education: National Aviation University, Kyiv, Ukraine, (2018).

Research area: Information Systems, Identification of Complex Systems.

E-mail: mila.gladka.26@gmail.com

А. П. Козлов, Л. С. Гладка. Високоточна бортова система керування та вимірювання рівня палива

Розглядаються паливо-вимірювальні системи сучасних повітряних суден. Показано необхідність їх подальшого удосконалення згідно рекомендаціям ІКАО. Наведено короткий огляд методів та засобів вимірювання рівня палива в баках в сучасних авіаційних паливомірах. Пропонується розробка та створення високоточного витратоміра повітря та розробки структури ПВС на основі вимірювання витрат надпаливного повітря у баках-кесонах з автоматичною стабілізацією тиску повітря в баці. Розглядаються конструкції діафрагменного вузла та диференціального манометра, що входять до об'ємометричної паливо-вимірювальної системи. Дається опис структури системи та її функціонування. Розроблена система дозволяє створити обладнання з покращеними характеристиками.

Ключові слова: паливо-вимірювальна система; рівнеміри; авіаційні паливоміри; об'ємометричний метод; діафрагменний вузол; диференціальний манометр; бак-кесон.

Козлов Анатолий Павлович. Кандидат технических наук. Доцент.

Кафедра авиационных компьютерно-интегрированных комплексов, Навчально-науковий інститут інформаційно-діагностичних систем, Національний авіаційний університет, Київ, Україна.

Освіта: Київський державний університет ім. Т. Г. Шевченко, Київ, Україна, (1965).

Область досліджень: ємнісні перетворювачі з неоднорідним магнітним полем, технологічні вимірювання, авіаційні прилади та інформаційні системи, проектування систем автоматизації.

Публікації: більше 50 робіт.

E-mail: ap_kozlov@ukr.net

Гладка Людмила Сергіївна. Магістр.

Кафедра авиационных компьютерно-интегрированных комплексов, Навчально-науковий інститут інформаційно-діагностичних систем, Національний авіаційний університет, Київ, Україна.

Освіта: Національний авіаційний університет, Київ, Україна (2018).

Область досліджень: інформаційні системи, ідентифікація складних систем.

E-mail: mila.gladka.26@gmail.com

А. П. Козлов, Л. С. Гладка. Высокоточная бортовая система управления и измерения уровня топлива

Рассмотрены топливно-измерительные системы современных воздушных судов. Показана необходимость их дальнейшего совершенствования в соответствии с рекомендациями ИКАО. Приведен короткий обзор методов и средств измерения уровня топлива в баках в современных авиационных топливомерах. Предложена разработка и создание высокоточного расходомера воздуха и разработка структуры топливно-измерительной системы на основе измерения расхода надтопливного воздуха в баках-кессонах с автоматической стабилизацией давления воздуха в баке. Рассматриваются конструкции диафрагменного узла и дифференциального манометра, которые входят в состав объемметрической топливно-измерительной системы. Дано описание структуры системы и ее функционирования. Разработанная система позволяет создать оборудование с улучшенными характеристиками.

Ключевые слова: топливно-измерительная система; уровнемеры; авиационные топливомеры; объемметрический метод; диафрагменный узел; дифференциальный манометр; бак-кессон.

Козлов Анатолий Павлович. Кандидат технических наук. Доцент.

Кафедра авиационных компьютерно-интегрированных комплексов, Учебно-научный институт информационно-диагностических систем, Национальный авиационный университет, Киев, Украина.

Образование: Киевский государственный университет им. Т. Шевченко, Киев, Украина, (1965).

Область исследований: емкостные преобразователи с неоднородным магнитным полем, технологические измерения, авиационные приборы и информационные системы, проектирование систем автоматизации.

Публикации: более 50 работ.

E-mail: ap_kozlov@ukr.net

Гладка Людмила Сергеевна. Магистр.

Кафедра авиационных компьютерно-интегрированных комплексов, Учебно-научный институт информационно-диагностических систем, Национальный авиационный университет, Киев, Украина.

Образование: Национальный авиационный университет, Киев, Украина, (2018).

Область исследований: информационные системы, идентификация сложных систем.

E-mail: mila.gladka.26@gmail.com