

UDC65.011.56:633.1 (045)

<sup>1</sup>V. M. Sineglazov,  
<sup>2</sup>D. V. Tkachenko**DOUBLE LAYER INTELLECTUAL CONTROL SYSTEM FOR QUALITY ASSURANCE  
OF SOLAR PANELS AND PHOTOVOLTAIC ELEMENTS**<sup>1,2</sup>Educational & Research Institute of Information and Diagnostic Systems, National Aviation University,  
Kyiv, UkraineE-mails: <sup>1</sup>svm@nau.edu.ua, <sup>2</sup>seraphim2369@icloud.com

**Abstract**—Studied the degradation rate and characteristics of solar cells. Developed the algorithm for solar cell characteristic analysis. Developed system for real time tracking and analysis of solar panel volt-ampere characteristics.

**Index Terms**—Degradation; complex system; intellectual system; real-time measurement and control; microcontroller.

**I. INTRODUCTION**

Using alternative sources of energy became important part of modern world. As for now it is clearly seen that the solar energy is one of most affordable and reliable source. However, despite that the solar panels have tendency to degrade, thus losing the efficiency of energy production. On behalf of that it is necessary to control the state of photovoltaic elements in real time to prevent any malfunction.

**II. PROBLEM STATEMENT**

To control the state of solar panels there are few methods present to use for now. All of them are mainly based on volt-ampere characteristics (VAC) of the solar panels. Regardless, it is not always necessary to receive the full VAC on solar panel in real time as it also will bring huge load on the system.

The development of the system will be divided in few steps, according to the hardware used development of the:

- 1) lower-level system that will measure all of the characteristics and will mostly act like a sensor;
- 2) higher level system, that will analyze the results across the massive of solar panels;
- 3) reliable connection between them and the remote connection from the handheld devices.

General requirements for the lower level system are: reliable Analogue to Digital Converter (ADC), ease of use, low power consumption, General Purpose Input-Output (GPIO) versatility [1].

**III. DEVELOPMENT OF LOWER LEVEL SYSTEM  
FOR QUALITY ASSURANCE CONTROL**

Lower level system will be including Arduino based board (Nano or Micro), Hall effect current

sensor that will be placed in-line from panel. Arduino was chosen for its fast analogue data gathering as Raspberry will need a decent amount of time to proceed with the values. Also interfacing with analogue data source is much less complicated than Raspberry.

Used Hall effect current sensor can measure up to 20A DC/AC current, what gives a vast opportunity for different systems.

For voltage measuring purposes we will be using Arduino itself with the relative voltage divider. Idea behind the voltage divider is that Arduino can measure only up to 5 V DC, meaning there is no way for us to use it for PE (Photovoltaic element), so in order to bypass this we will use voltage divide that will allow us to use Arduino with up to 55 V DC source. That will allow to hook up the system to almost any solar panel module that is present on the market.

**IV. STRUCTURAL SCHEME OF THE LOWER  
LEVEL SYSTEM**

If the Arduino is powered from an external power supply or a USB cable (i.e. not powered by a isolated battery or other isolated power supply) the circuit may share a common ground or 0 V connection with the circuit under test.

If the GND connection of the Arduino is connected to any other part of the circuit under test except GND, then this is the same as shorting that part of the circuit to GND.

The GND of the Arduino is like the negative or common (COM) lead of a multimeter, except that it should be considered to be permanently connected to the GND of the circuit under test for safety, unless the Arduino or the circuit under test is completely isolated and "floating".

The resistor values in the circuit diagram above provide some over-voltage protection when

measuring low voltages such as 5 V, 9 V or 12 V. So if a voltage of say 30 V is accidentally measured, it will not blow the Arduino analog input pin.

Any voltage higher than about 1000 V could damage the Arduino. The point on the resistor divider network connected to the the Arduino analog pin is equivalent to the input voltage divided by 200, so 1000 V/200 = 5 V. In other words, when measuring 1000 V, the Arduino analog pin will be at its maximum voltage of 5 V.

Providing this basic over-voltage protection is at the expense of not using the full 10-bit range of the analog input ADC if only lower voltages are to be measured, but changes of about 0.054 V can still be measured.

No other protection for voltage spikes, reverse voltage or voltages higher than 55 V is shown in the circuit. From what can be seen on the curcuit (Fig. 1).

Basically the Arduino measures the input at the analog pin, converts it to millivolts, subtracts the offset and then finally divides it by the scale factor of the current sensor.

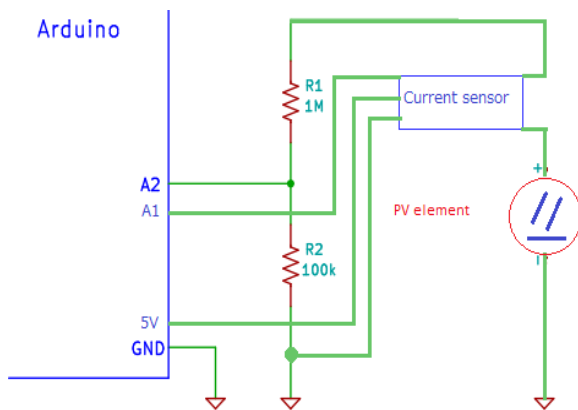

Fig. 1. Lower level system main circuit

In other words, it's nothing more than a simple Arduino voltmeter that interprets the output of the ACS712.

The program then makes use of the Arduino Serial Monitor to look at the results.

Notice that increasing the voltage increases the current.

Otherwise, Ohms' law can be used [2].

V. MAIN PRINCIPLE OF OPERATION

The current-voltage characteristic of a solar cell is a superposition of the current-voltage characteristic of a diode in the dark and the light current of the solar cell.

Under the influence of light, the volt-ampere characteristic is shifted downward into the fourth quarter, in which the useful power is located. Lighting Solar Element (SE) adds a light current to

the dark current and the equation of the diode takes the form:

$$I = I_0 \left[ \exp\left(\frac{qV}{nkT}\right) - 1 \right] - I_L,$$

where  $I_L$  is the light current.

Effect of light on the current-voltage characteristic of the *p-n*-junction (Fig. 2.)

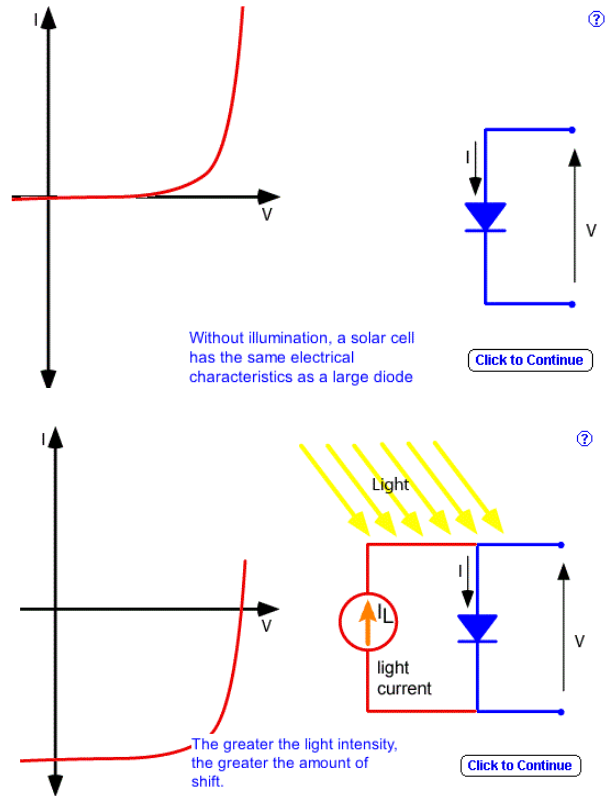

Fig. 2 Effect of light on the current-voltage characteristic of the *p n*-junction

The equation of the current-voltage characteristic in the first quarter is written as

$$I = I_L - I_0 \left[ \exp\left(\frac{qV}{nkT}\right) - 1 \right].$$

The term (-1) in this equation can usually be neglected. The exponential component is usually  $\gg 1$  for all voltages except very small (less than 100 mV). At low voltages, the light current  $I_L$  prevails over the current  $I_0$  (...), therefore (-1) can be omitted.

Received data:

- dark current,  $I_0 = 1 \times 10^{-10}$  A;
- light current,  $I_L = 0.5$  A;
- the coefficient of ideality,  $n = 1$ ;
- temperature,  $T = 300$  K;
- voltage,  $V = 0.5$  V;
- current,  $I = 0.4753$  A.

Next, we discuss some important parameters used to characterize the solar cell. The main ones are the short-circuit current ( $I_{SC}$ ), the no-load voltage ( $V_{OC}$ ), the duty cycle (FF) and the efficiency. These parameters can be calculated from the current-voltage characteristic.

The short-circuit current is the current flowing through the solar cell when the voltage is zero (i.e., when the SE is short-circuited). The short-circuit current is usually referred to as  $I_{SC}$ . The graphical representation is provided below (Fig. 3).

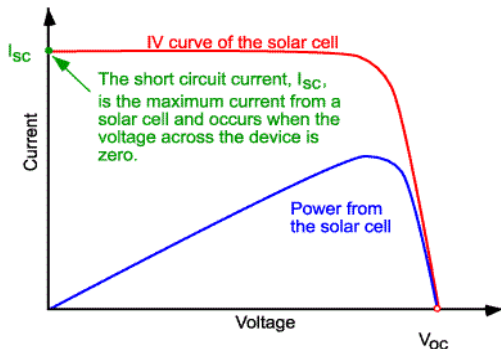

Fig. 3. Short-circuit current on the current-voltage characteristic

The short-circuit current arises from the generation and separation of light-generated carriers. In an ideal SE, under the condition of moderate resistive losses, the short-circuit current is equal to the light current. Therefore, the short-circuit current can be considered the maximum current that the solar cell can generate.

## VI. CONCLUSION

The need in monitoring the solar cells is in need as the world shifting to the usage of the solar energy. This particular system will allow to monitor the state of the element in the real time scale informing regarding any defect that may present at the moment.

The system is self-developing according to the received data, thus the accuracy and response rate will only increase over time.

## REFERENCES

- [1] Solar panels efficiency <https://www.wholesolar.com/solar-information/solar-panel-efficiency>
- [2] Arduino manuals [www.arduino.cc](http://www.arduino.cc)

Received November 14, 2016

**Sineglazov Viktor.** Doctor of Engineering Science. Professor.

Educational & Scientific Institute of Information and Diagnostic Systems, Aviation Computer-Integrated Complexes Department, National Aviation University, Kyiv, Ukraine.

Education: Kyiv Polytechnic Institute, Kyiv, Ukraine (1973).

Research area: Air Navigation, Air Traffic Control, Identification of Complex Systems, Wind/Solar power plant.

Publications: more than 600 papers.

E-mail: [svm@nau.edu.ua](mailto:svm@nau.edu.ua)

**Denis Tkachenko.** Student.

Educational & Scientific Institute of Information and Diagnostic Systems, Aviation Computer-Integrated Complexes Department, National Aviation University, Kyiv, Ukraine.

Education: National Aviation University, Kyiv, Ukraine (2017).

Research area: Complex Systems, Intellectual systems, Photovoltaic elements, Neural networks.

Publications: 1.

E-mail: [seraphim2369@icloud.com](mailto:seraphim2369@icloud.com)

**В. М. Синєглазов, Д. В. Ткаченко. Дворівнева інтелектуальна система контролю роботи сонячних панелей**

Розглянуто рівень деградації та основні характеристики сонячних елементів. Розроблено алгоритм для аналізу характеристик сонячних елементів. Розроблено систему для моніторингу та аналізу характеристик панелей в реальному часі.

**Ключові слова:** система контролю; комплекс; вольт-амперна характеристика; інтелектуальна система; вимір і аналіз даних в реальному часі; мікроконтролер.

**Синєглазов Віктор Михайлович.** Доктор технічних наук. Професор.

Навчально-науковий інститут інформаційно-діагностичних систем, кафедра авіаційних комп'ютерно-інтегрованих комплексів, Національний авіаційний університет, Київ, Україна.

Освіта: Київський політехнічний інститут, Київ, Україна (1973).

Напрямок наукової діяльності: аеронавігація, управління повітряним рухом, ідентифікація складних систем, вітроенергетичні установки.

Кількість публікацій: більше 600 наукових робіт.

E-mail: [svm@nau.edu.ua](mailto:svm@nau.edu.ua)

**Ткаченко Денис Вадимович.** Студент.

Навчально-науковий інститут інформаційно-діагностичних систем, кафедра авіаційних комп'ютерно-інтегрованих комплексів, Національний авіаційний університет, Київ, Україна.

Освіта: Національний авіаційний університет, Київ, Україна (2017).

Напрямок наукової діяльності: комплексні системи, інтелектуальні системи, фотовольтаїчні системи, нейронні мережі.

Кількість публікацій: 1.

E-mail: seraphim2369@icloud.com

**В. М. Синеглазов, Д. В. Ткаченко. Двухуровневая интеллектуальная система контроля работы солнечных панелей**

Рассмотрен уровень деградации и основные характеристики солнечных элементов. Разработан алгоритм для анализа характеристик солнечных элементов. Разработана система для мониторинга и анализа характеристик панелей в реальном времени.

**Ключевые слова:** система контроля, комплекс, вольт-амперная характеристика, интеллектуальная система, микроконтроллер, измерение и анализ данных в реальном времени, микроконтроллер.

**Синеглазов Виктор Михайлович.** Доктор технических наук. Профессор.

Учебно-научный институт информационно-диагностических систем, кафедра авиационных компьютерно-интегрированных комплексов, Национальный авиационный университет, Киев, Украина.

Образование: Киевский политехнический институт, Киев, Украина (1973).

Направление научной деятельности: аэронавигация, управление воздушным движением, идентификация сложных систем, ветроэнергетические установки.

Количество публикаций: более 600 научных работ.

E-mail: svm@nau.edu.ua

**Ткаченко Денис Вадимович.** Студент.

Учебно-научный институт информационно-диагностических систем, кафедра авиационных компьютерно-интегрированных комплексов, Национальный авиационный университет, Киев, Украина.

Образование: Національний авіаційний університет, Київ, Україна (2017).

Направление научной деятельности: комплексные системы, интеллектуальные системы, фотоловольтайческие системы, нейронные сети

Количество публикаций: 1.

E-mail: seraphim2369@icloud.com