

COMPUTER-AIDED DESIGN SYSTEMS

UDC 629.3.025.2 (045)

O. A. Sushchenko

COMPUTER-AIDED DESIGN OF INERTIALLY STABILIZED PLATFORMS

 Educational-Scientific Institute of Air Navigation, National Aviation University, Kyiv, Ukraine
 E-mail: sushoa@ukr.net

Abstract—The method of synthesis of inertially stabilized platforms structure is proposed. The basic principles of dataware representation of the computer-aided procedure are given. The approach to formalized representation of inertially stabilized platform structure is represented. The obtained results may be useful for inertially stabilized platforms operated on vehicles of the wide class.

Index terms—Inertially stabilized platforms; synthesis of structure; theory of graphs; method of direct search.

I. INTRODUCTION

Nowadays inertially stabilized platforms (ISPs) are widely used in many technical areas due to their ability to stabilize and point information and measuring systems such as cameras, antennas, and so on. Their applications include surveillance, tracking, communications, and monitoring. Visible and infrared cameras are pointed and held stable by ISPs on ground vehicles, marine vehicles, unmanned aerial vehicles, aircraft, and spacecraft for various missions such as mapping, and providing high-resolution imagery for environmental surveys. ISPs can operate on vehicles to stabilize and point communication antennas. A payload to be stabilized is mounted directly on the gimballed platform. Typically, ISP must be designed to point and stabilize the payload about two or more axes, but the most applications require at least two orthogonal gimbals. Stabilization and control of the platform motion are implemented by means of the servo-systems consisting of the gyro sensors, controllers and actuators [1].

The process of modern ISPs creation is characterized by requirements to design time decrease and extension of functionality. To satisfy these conflicting requirements is impossible without using computer-aided design procedures. It worth to notice, that problems of synthesis of ISP structure are not still researched on the necessary level. Although general principles of development of computer-aided design systems are given in [2]. Features of computer-aided design of controls systems are represented in [3]. Computer-aided design of robust controllers of ISP systems is described in [4]. The above listed books and papers can be used as fundamentals for development of the method of ISP structure synthesis.

Although requirements to ISPs vary widely depending on the application, they have common features. Design of ISP includes analysis of specification

of requirements, synthesis of system structure, development of the mathematical model, design of a controller. These procedures are implemented in the early stages of design. In many cases, they are based on experience in development of prototype systems. Next design procedures include calculations of characteristics, division of the system into separate units, and development of specifications of requirements to these units. Moreover, design and technological developments, prototyping, and tests are carried out. The scheme of ISP design process is represented in Fig. 1 [2].

II. PROBLEM STATEMENT

Optimal choice of system structure lies in determination of the finite sets of subsystems and their structural connections, for which some objective function is minimized. This objective function represents the most important characteristic of the designed system. The obtained solution must satisfy other requirements given to the designed system.

The optimization problem of system structure choice can be represented in the following form

$$\max_{S_i \subset S} g[k_l(x_j)] \quad \forall(j) (x_j \in X_{\text{per}}), \quad (1)$$

here S is a set of permissible variants of system structure; $k_l, l = \overline{1, m}$ are quality indices; $x_j, j = \overline{1, n}$ are system parameters and characteristics; X_{per} is a set of the system permissible values.

The alternative variants of ISP structure are vector-incomparable. It means that it is impossible to use the Pareto criterion, which may be represented in the following form

$$\forall(i) [k_{li}(S_1) \leq k_{2i}(S_2)] \quad \text{and} \quad \exists(i) [k_{li}(S_1) \leq k_{2i}(S_2)]. \quad (2)$$

For the optimization problem (1) the expressions (2) define conditions, in which the system S_1 has advantages in comparison with the system S_2 . Here k_{1i}, k_{2i} are normalized quality indices of systems S_1, S_2 . The system with lower values of quality indices is considered to be better. In accordance with the Pareto criterion, all values of the quality indices of the first variant must be not worse than appropriate

indices of the second variant. And at least one quality index must be better. In practical situations indices of the first system quality may be both worse and better than indices of the second system quality. This causes the necessity to use the conditional criteria. Moreover, problems of ISP system structure optimization are multi-criteria. And their dimensionality may be decreased by means of usage of generalized quality indices.

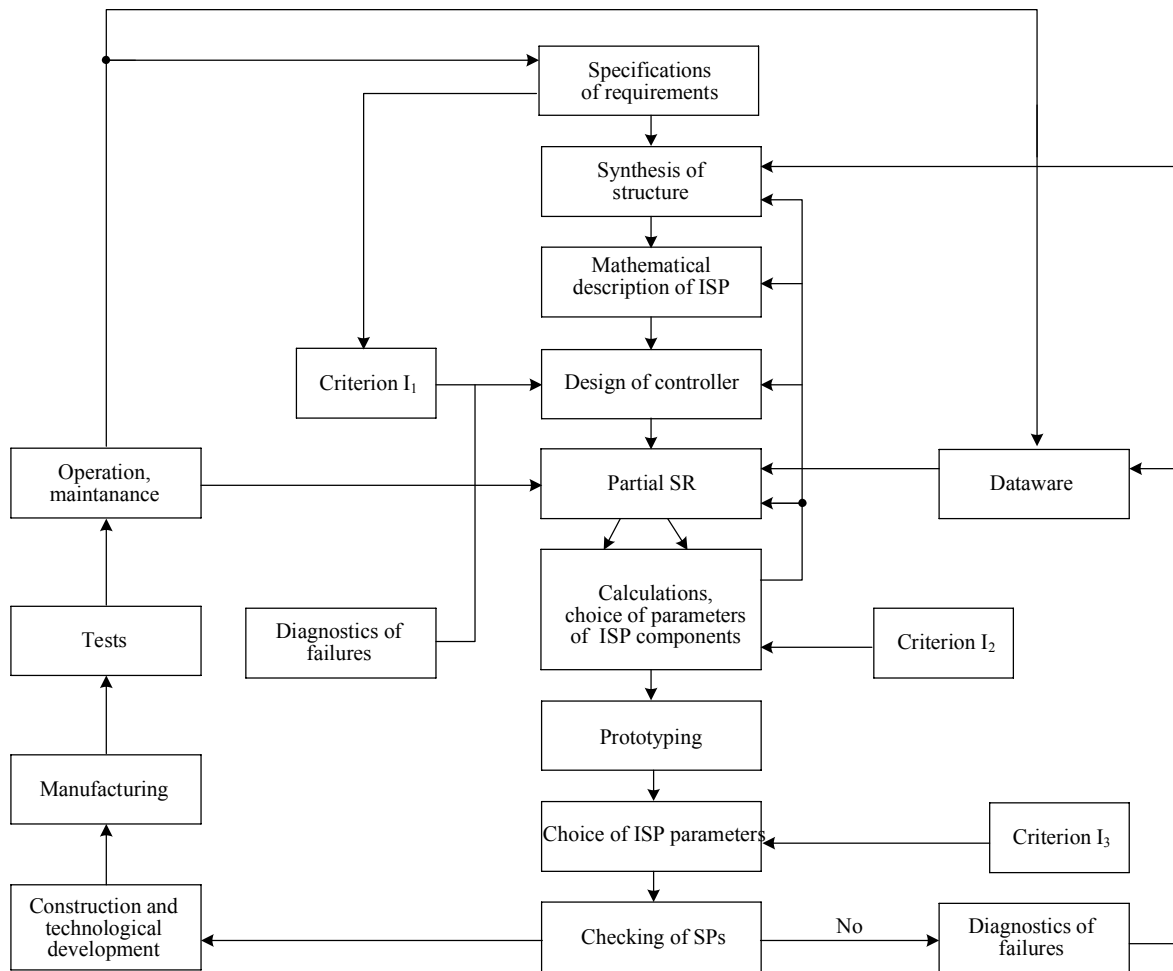

Fig. 1. Scheme of ISP design process: SP is the specification of requirements

Synthesis of ISP structure may be solved from the point of view of the maximum reliability achievement. Requirements to operation characteristics including mass and dimensions must be satisfied too. This problem statement may be represented in the following form

$$\max P(\mathbf{X}) = \prod_{i=1}^n P(x_i), \mathbf{X} \in D_x;$$

$$D_x = \{\mathbf{X} | V(\cdot) < V_{\text{per}}, \Delta(\cdot) \leq \Delta_{\text{per}}\},$$

statement (4) such quality indices as accuracy, reliability, mass, dimensions, and cost must satisfy requirements given to the system. These constraints must be represented in the form of inequalities.

Problem statement (3) requires solving some basic tasks such as forming of dataware, formalized representation of system structure and realization of synthesis procedure.

III. FORMING OF DATAWARE

The above state problems may be solved using experience of a designer and computer-aided design procedures. Solution of the above stated tasks is based on the multiobjective optimization. Nevertheless they may be formulated in the first approximation as one-objective optimization problems and other objectives will be used as constraints.

Design of ISP requires the choice of its structure, parameters and hardware implementation, which satisfy requirements given to the system. As a rule, such various requirements include accuracy, static

and dynamic characteristics, margin, resistance to external disturbances, reliability, mass and dimensions, power requirements, conditions of manufacturing, transportation, storage, and operation.

The paper deals with synthesis of ISP structure. For this it is necessary to analyze information about ISP components, which are represented in Fig. 2 [4].

Computer-aided solving of the listed tasks requires development of the appropriate dataware. It must include information about ISP functions, sensors and units, which can implement these functions, and also characteristics of these sensors and units. Partial dataware on example of such function as measurement of angular rates is represented in Table I.

To create the formalized description it is necessary to analyze functions of the designed system and structural units necessary for their implementation. The matrix of executable functions **A** and column matrix of redundant realizations **B** (Table II) can be formed based on this analysis.

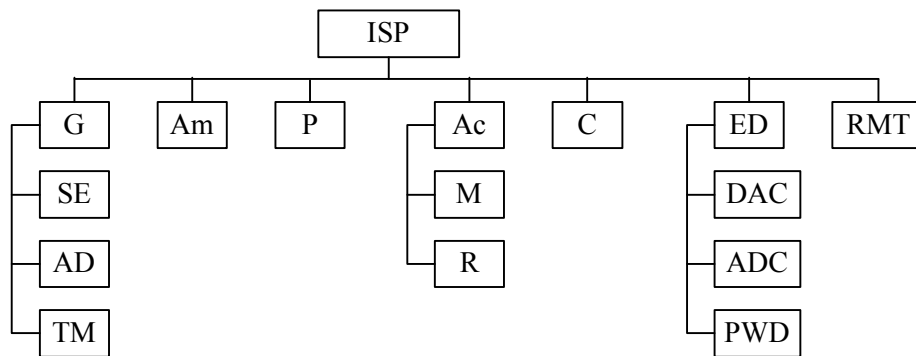

Fig. 2. ISP components: G is a gyro, which includes a sensitive element (SE), angle-data transmitter (AD), torque motor (TM); Am is an accelerometer; P is a gimbaled platform with payload; Ac is an actuator, which includes a motor (M) and a reducer (R); C is a controller; ED are electronic devices including digital-analog converter (DAC), analog-digital converter (ADC); pulse width modulator (PWM); RMT is a relative-motion transducer

TABLE I

DATAWARE OF REALIZABLE FUNCTIONS (ON EXAMPLE OF ANGULAR RATE MEASUREMENT)

Function	Sensor	Characteristics
Measurement of angular rate	GT-46	1.Measurement range. 2.Threshold of sensitivity. 3.Resistance to shocks. 4.Mass and dimensions. 5.Cost.
	MEMS	
	FOG	
	CVG	

TABLE II

MATRICES OF EXECUTABLE FUNCTIONS AND REDUNDANT REALIZATIONS

N _o	Functions of the system	Elements of matrix A	Structural unit	Elements of vector B
1	Measurement of angular rate	ω	Rate gyro	GT-46, G20-075-100, SDG1000, MAG16, VG910F, CVG
2	Forming of control actions	U	Motor	EDM02, EDM14, EDM20, MBEPPS-K, DPM-1,6-110-D09
3	Forming of control signal (controller output)	U_c	Controller	PID, PI, H_∞

IV. FORMALIZED DESCRIPTION OF STRUCTURE

To formalize the system structure description, the designed system is believed to have m functions, which can be implemented by n devices with known characteristics. The problem lies in choice of such set of devices, which provides extremum of the most important characteristic and satisfaction of other requirements given to the system. The most important quality index is chosen by a designer. It depends on the goal and phase of design.

One of known approaches to formalized description of system structure [2] lies in using the mathematical model with Boolean variables, which can be created by means of the discrete programming

$$x_j = \begin{cases} 1 & \text{if } j\text{th device is the system component,} \\ 0 & \text{otherwise.} \end{cases} \quad (5)$$

Characteristics of ISP components are stored in dataware of the computer-aided design system.

To solve the represented problem it is necessary to create the formalized description of the generalized system with redundant functions. In this case, description of functions and possible technical realizations is implemented on the level of the system structural units. Such formalized description can be represented in the form of the rectangular matrix of functions \mathbf{A} and the column matrix of redundant realizations \mathbf{B} . The matrix of necessary functions realizations may be determined by the expression $\mathbf{C}=\mathbf{AB}$. The matrix \mathbf{C} describes the basic structure of the designed system. Such approach allows determining necessary set of system structural units based on the requirements given to the designed system. But the above stated approach does not take into consideration structural connections between units of the searched structure. Such situation may be improved by means of the graph theory. The structural scheme of the system with redundant functions can be described by the oriented weighted graph

$$G_0 = (W_0, F_0), \quad \text{where } W_0 \text{ is a set of nodes, } F_0 \text{ is a set of arcs.} \quad (6)$$

here W_0 is a set of the graph nodes, which corresponds to a set of the system structural units; F_0 is a set of graph arcs with orientation corresponding to direction of signals passing in the system. Weighting coefficients of the graph nodes

In this case, environment is considered to be external devices and measured signals.

During deletion of nodes, which correspond to devices carrying out functions of signal transformation, input arcs become output ones. Therefore in this case for transition from the matrix D_0 to the matrix D it is necessary to carry out two from above stated rules. Further it is necessary to change rows possessed unit negative elements with their sums with the nearest rows deleted during execution of the point 1.

During deletion of nodes, which correspond to devices carrying out functions of signal measurement, it is necessary to delete columns with numbers corresponding to unusable connections. Such operation corresponds to deletion of the certain arcs of the oriented graph G_0 . The above stated rules of the oriented graph transformation are represented in Fig. 3.

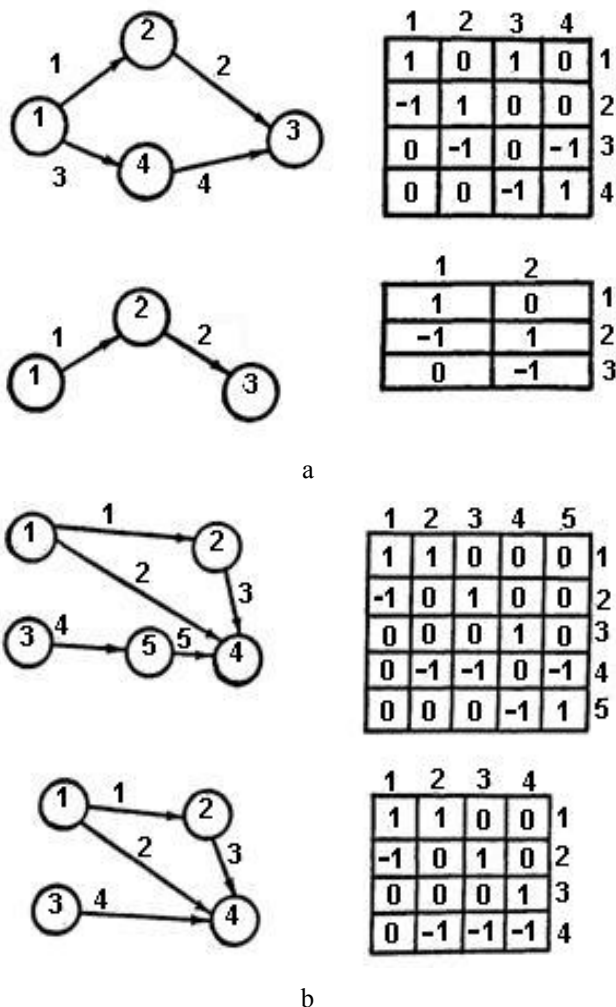

Fig. 3. Rules of transformation of the oriented graph for measuring (a) and converting (b) devices

These rules and expressions (5) – (8) allow to automatize the process of structural scheme implementation.

V. SYNTHESIS OF SYSTEM STRUCTURE

Design of complex systems including ISPs requires solving many optimization problems. Choice of the system components is one of such tasks. This problem has some features. In the first place, this task is weakly formalized. In the second place, this task can not be fully formalized, because a designer makes finite decisions about accepted solutions. And the designer may change his decisions based on new information entering during design. It is obviously, that this task must be solved in the interactive mode.

Constraints for the considered optimization problem must be given in the linear form

$$C = \sum_{j=1}^n c_j x_j ; V = \sum_{j=1}^n v_j x_j ; G = \sum_{j=1}^n g_j x_j ;$$

$$\Lambda = \sum_{j=1}^n \lambda_j x_j ,$$

here c, v, g, λ are cost, volume, mass and failure rate of every j th device. It is worth notice, that quantity of possible variants of ISP structure is limited. So, choice of ISP structure and components can be implemented by means of the direct search of possible variants of the system structure. The algorithm of ISP structure synthesis directed to achievement of the maximum reliability includes the following steps.

1. Choice of a variant of the structure using dataware.
2. Creation of the incidence and adjacency matrices describing the system structure.
3. Search of the least reliable structural unit at change it by the more reliable one.
4. Change of the incidence and adjacency matrices describing the system structure.
5. Checking of other requirements given to the system.
6. Repetition of the previous steps until determination of the structure corresponding to the most reliable system.

Problem of optimization of the system structure and choice of ISP components requires dataware including information about characteristics of the structural units. This allows developing various variants of the designed system structure.

The optimization problem is solved in the interactive mode. The user interface must provide choosing of method of problem optimization and observing of the intermediate results.

VI. CONCLUSIONS

The approach to ISP structure synthesis is proposed. The way to formalize the system structure description is represented. Features of the appropriate dataware are described.

REFERENCES

- [1] J. M. Hilkert, "Inertially stabilized platform technology". *IEEE Control Systems Magazine*, vol. 26, no. 1, 2008, pp. 26–46.
- [2] I. P. Norenkov, *Computer-Aided Design*. Moscow, MSTU named after N.E Bauman Publ., 2000, 188 p. (in Russian)
- [3] P. I. Solnitsev, *Automation of control systems design*, Moscow, Vishaya shkola Publ., 1991, 335 p. (in Russian)
- [4] O. A. Sushchenko, "Computer-aided design of robust system for stabilization of information and measuring devices at moving base". *Proceedings of the National Aviation University*, no. 3, 2013, pp. 41–48.
- [5] J. A. Bondy and U. S. R. Murty, *Graph theory with applications*, New York, North-Holland, 1982, 249 p.

Received January 18, 2016

Sushchenko Olha. Doctor of engineering. The associate professor.

The Aircraft Control Systems Department, National Aviation University, Education and Scientific Institute of Air Navigation, Kyiv, Ukraine.

Education: Kyiv Politechnic Institute, Kyiv, Ukraine. (1980)

Research interests: systems for stabilization of information and measuring devices operated at vehicles of the wide class.

Publications: 120.

E-mail: sushoa@ukr.net

О. А. Сущенко. Автоматизоване проектування інерціальних стабілізованих платформ

Запропоновано метод синтезу структури інерціальних стабілізованих платформ. Наведено основні принципи формування інформаційного забезпечення автоматизованої процедури проектування. Представлено підхід до формалізованого представлення структури та алгоритм її синтезу. Отримані результати можуть бути корисними для проектування інерціальних стабілізованих платформ, що функціонують на рухомих об'єктах широкого класу.

Ключові слова: інерціальні стабілізовані платформи; синтез структури; теорія графів; метод прямого пошуку.

Сущенко Ольга Андріївна. Доктор технічних наук. Доцент.

Кафедра систем управління літальних апаратів, Національний авіаційний університет, Навчально-науковий інститут аеронавігації, Київ, Україна.

Освіта: Київський політехнічний інститут, Київ, Україна (1980).

Напрямок наукової діяльності: системи стабілізації інформаційно-вимірювальних пристроїв, експлуатованих на рухомих об'єктах широкого класу.

Кількість публікацій: 120.

E-mail: sushoa@ukr.net

О. А. Сущенко. Автоматизированное проектирование инерциальных стабилизированных платформ

Предложен метод синтеза структуры инерциальных стабилизированных платформ. Даны основные принципы формирования информационного обеспечения автоматизированной процедуры проектирования. Представлен подход к формализованному представлению структуры и алгоритм ее синтеза. Полученные результаты могут быть полезными для проектирования инерциальных стабилизированных платформ, функционирующих на подвижных объектах широкого класса.

Ключевые слова: инерциальные стабилизированные платформы; синтез структуры; теория графов; метод прямого поиска.

Сущенко Ольга Андреевна. Доктор технических наук. Доцент.

Кафедра систем управления летательных аппаратов, Национальный авиационный университет, Учебно-научный институт аэронавигации, Киев, Украина.

Образование: Киевский политехнический институт, Киев, Украина (1980).

Направление научной деятельности: системы стабилизации информационно-измерительных устройств, эксплуатируемых на подвижных объектах широкого класса.

Количество публикаций: 120.

E-mail: sushoa@ukr.net